

Design of an Efficient Triple Band RF Energy Harvester

Yunus Uzun

Department of Electrical and Electronics Engineering
Faculty of Engineering, Aksaray University, Aksaray, 68100, Turkey
yunusuzun@aksaray.edu.tr

Abstract — In this paper, a new triple band RF energy harvester, considering all the influential parameters, is designed by using Advanced Design System (ADS) simulation software. The most important problem in the RF energy harvesters is low system efficiency. Another problem is that these circuits work on narrow RF bands. The proposed design is found to be much efficient with its current form and provide broadband working frequencies. The output power values and efficiencies of each circuit have been obtained from the software by varying input RF power, load resistance and the number of stages in voltage multiplier at DTV 575 MHz, GSM 900 MHz and WiFi 2.45 GHz frequencies. Thereby a triple band RF energy harvester is proposed for higher efficiency. The system efficiencies for this input power level are obtained about 55% at 575 MHz, 45% at 900 MHz, 30% at 2.45 GHz. The average efficiency is found to be 43% for the individual systems. However, the system efficiency is 68% in the proposed triple band RF energy harvester. This corresponds to an increase rate of 58% for the efficiency. Furthermore, thanks to the proposed RF energy harvester, the efficiencies are increased significantly in cases which only one or two RF signals exist.

Index Terms — Efficiency, impedance matching, RF energy harvester, triple band, voltage multiplier.

I. INTRODUCTION

Wireless sensors become very important for our daily life. In general, they consume a little amount of power. These devices are often fed by the batteries. However, the batteries have some disadvantages such as requiring replacement in certain times, increasing the size of device and causing environment pollution [1-5]. In some cases, it is difficult or impossible to replace the batteries of wireless sensors, so lifetime of these devices is equivalent to the lifetime of their batteries [6-8]. These problems motivate the researchers to develop new technologies [9,10]. Recently, low power energy generation methods such as vibration (piezoelectric, electromagnetic and electrostatic), thermoelectric and RF energy harvesting draw attention in terms of an

alternative energy source to the batteries. These energy harvesting methods provide a usage without the batteries or an increased battery life of the wireless sensors [11]. There are many signals of different frequencies in our environment, because the wireless communication and equipments are used widely. RF signal sources are TV and radio transmitters, mobile base stations, mobile phones and the other wireless systems [12,13]. It is possible to generate the electrical energy by using RF signals with the properly-designed systems [14,15]. This energy generation method is called RF energy harvesting or RF energy scavenging.

RF energy harvesting method can be especially useful for wireless sensor nodes located in remote places where other energy sources are not feasible [16,17]. Moreover, RF energy harvesting, compared to other energy harvesting methods such as wind and solar etc., does not depend on nature and is available continuously; thus, it is a relatively predictable energy form [18,19]. The main idea of the RF energy harvesting system is capturing RF energy in our surroundings. This energy can supply the electronic equipments with low power consumption or can be stored for future usage [20,21]. Fundamentally, RF energy harvesters include an efficient antenna and an electronic circuit which converts an RF signal to a DC signal. Additionally, source impedance must be equal to the circuit impedance for the maximum power, so an impedance matching circuit is vital in order to obtain the maximum power.

The basic RF energy harvesting system is shown in Fig. 1, which consists of matching circuit, voltage multiplier (RF to DC converter) and storage and load circuits.

The harvested power depends on the RF power level, antenna of system, frequency band and RF to DC converter circuit. Actually, the bases of RF energy harvester are an electromagnetic induction system. So, the higher the RF power, the higher the obtained power. The high gain of the selected antenna and the selection of appropriate frequency band increase the power obtained from the system. In addition, the use of appropriate RF to DC converter and matching circuits

improve on system efficiency.

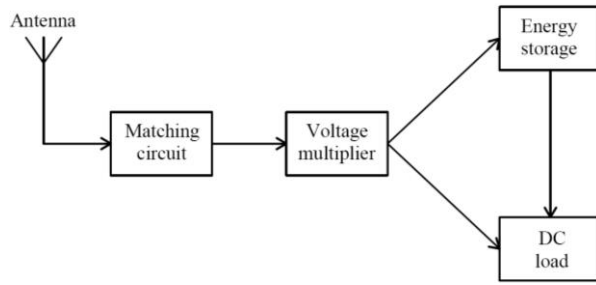

Fig. 1. The block diagram of an RF energy harvesting circuit.

In a wireless system, the received power can be theoretically calculated by the Friis transmission equation as shown in Equation (1):

$$P_r = P_t G_t G_r \left[\frac{\lambda}{4\pi R} \right]^2, \quad (1)$$

where P_r is received power, P_t is transmitted power, G_t is gain of the source antenna, G_r is gain of the receiver antenna, λ is wavelength of the transmitted signal, and R is distance between the source and receiver.

As shown in Equation (1), the received power decreases as the distance increases. Therefore, this situation is an important difficulty for the RF energy harvesting concept in far places. Thus, the necessary optimizations should be performed very well to obtain high efficiencies from the system. Considering that the RF signal levels are low in the media, in particular, the impedance matching process should be done properly. In addition, owing to the fact that there are a large number of RF signals at different levels and frequencies in the surrounding media, the increment of the obtained power using the systems that can generate energy from multiple signals is very beneficial.

In this paper, the RF energy harvesters, having three different frequencies which are Digital TV (575 MHz), GSM (900 MHz) and WiFi (2,45 GHz), are analyzed for the voltage multipliers having different number of stages, load impedances, input frequencies and input RF powers using the ADS software. Later, an integrated triple band RF energy harvester being capable of generating energy in the aforementioned frequencies is designed. Thus, optimum parameters for an effective RF energy harvester are determined. And an important increase is obtained in the efficiency using triple band RF energy harvester. In the literature, there are some works including more than one frequency band. 63% efficiency is obtained using a triple band RF energy harvester in Phams' work [22]. Keyrouz *et al.* [23] have designed a triple band RF energy harvester which is combined three different RF energy harvester. The maximum efficiency is 46% in this work. The

system efficiency of a dual band RF energy harvester is 57% in Kim *et al.* [24]. The efficiency of proposed system was measured as 68%. This rate is an important improvement in terms of the system efficiency. In addition to this improvement, this RF energy harvester provides high efficiency increase in cases which only one or two RF signals exist.

The paper is organized as follows: In Section 2, the RF energy harvester system including the impedance matching circuit and the voltage multiplier is introduced. In Section 3, some simulation results are presented for different parameters. Finally, the concluding remarks are presented in the last section.

II. ENERGY HARVESTING SYSTEM

RF energy harvester system consists of an antenna, an impedance matching circuit (IMC), a voltage multiplier circuit (VMC), a storage circuit and a load circuit. Antenna with high gain and appropriate frequency band is very important in order to get energy efficiently from the media. Obtained power by an RF energy harvester cannot be sufficient for a load circuit. Due to that, a storage unit must be used to store the obtained energy.

Figure 2 (b) shows a simple 900 MHz RF energy harvester including the L type impedance matching circuit and one stage voltage multiplier. The component values of the impedance matching circuit are determined by the software and also calculated analytically by using the following equations [25]:

$$\frac{1}{X_{C_m}} = \frac{1}{Z_0} \sqrt{\frac{Z_0 - R_L}{R_L}}, \quad (2)$$

$$X_{L_m} = \sqrt{R_L(Z_0 - R_L)} - X_L. \quad (3)$$

Here, X_{C_m} and X_{L_m} are reactances of the impedance matching capacitor and inductor, respectively. Z_0 is input impedance (50 Ω), R_L is real part of the load impedance (31,46 Ω) and X_L is imaginary part of the load impedance (-j340,38 Ω). By solving the following equations, the impedance matching components C_m and L_m are found 2.71 pF and 64.46 nH, respectively.

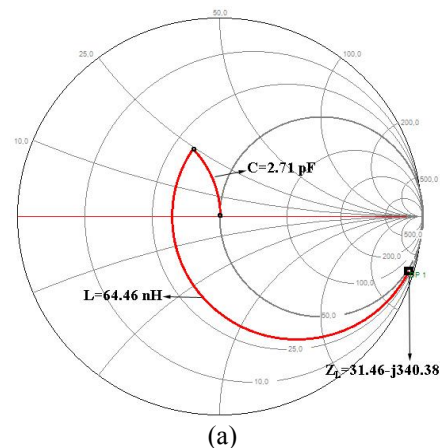

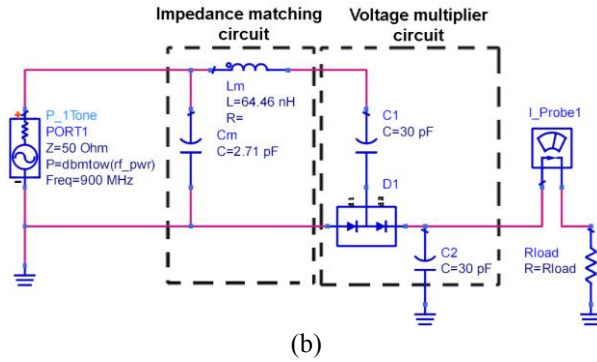

Fig. 2. (a) The Smith Chart diagram for impedance matching process. (b) 900 Mhz RF energy harvester included IMC and VMC.

In the simulations, this circuit is established at 575 MHz, 900 MHz and 2.45 GHz input frequencies for all number of stages. So, the component values of IMC are determined separately for each stage and input frequency.

A. Impedance matching circuit

In a transmission line, source and load impedances must be equalled to providing the maximum power transfer. Especially, when the input power is low, impedance matching circuits provide a great increase in the system efficiency. RF energy harvester systems should work on low input power levels, because the signal levels surrounding our environment are weak in general. This situation requires that the impedance matching circuits should be used to obtain increased power from such systems. These circuits can be performed in various ways. One of these ways is *L* type impedance matching circuit, which is simple and not bulky. *L* type impedance matching circuit is configured according to the ratio of the load impedance to source impedance.

There are an inductor and a capacitor at *L* type impedance matching circuits. The values of these components depend on the source and the load impedances. The values of components used in this work are shown in Table 1. In the proposed system, while the working frequency is higher, the impedance of the voltage multiplier (i.e., load impedance) is lower due to effect of saturation current. Thus, the values used in the impedance matching circuits are lower at high frequencies.

When the triple band energy harvester is used instead of individual system, total impedance matching component is reduced by 33% as shown in Table 1. Because four matching components are used in the proposed system (3 inductors and 1 capacitor), however the triple band system included three individual harvester use six matching component (3 inductors and

3 capacitors). That causes to decrease the cost and the size of the system. Even though there is an increase at the values of the inductors used in the impedance matching circuit, this situation is not an important increase in terms of cost and size.

Table 1: The components used in one stage individual and triple band energy harvesters

	L (nH)		C (pF)	
	Individual System	Triple Band System	Individual System	Triple Band System
575 MHz	127.2	207.5	0.1	-
900 MHz	64.5	86.0	2.7	-
2.45 GHz	8.6	13.7	2.6	1.6

B. Voltage multiplier circuit

A voltage multiplier circuit can be used to increase voltage signal obtained from the antenna. These circuits convert the RF signals into the DC voltage used in most of the electronic equipments. There are various voltage multiplier circuits. Dickson voltage multiplier circuit is shown in Fig. 3 for this study. The circuit consists of two diodes and two capacitors for each stage. HSMS-2852 Schottky diodes were used in this work due to they have fast switching speed, low forward voltage, low substrate leakage and relatively low junction capacitance. In addition, the system is not bulky, because these diode packages include two series diodes. Therefore, they are suitable for the voltage multiplier circuits.

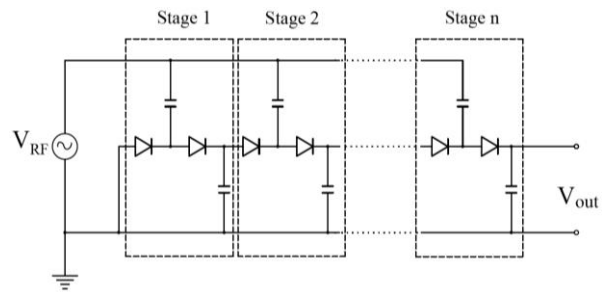

Fig. 3. n stage Dickson voltage multiplier.

The capacitors having different capacity are connected as stage components. But the output voltage does not change too much by using the capacitors that have equal or different capacitance at the stages. For simplicity, same value of the capacitances for all stages is selected. The number of voltage multiplier stages has a significant effect on the efficiency of the RF energy harvesting system [26].

Figure 4 shows equivalent circuit of the Schottky

diode. The overall impedance value of the diode depends on too many variables.

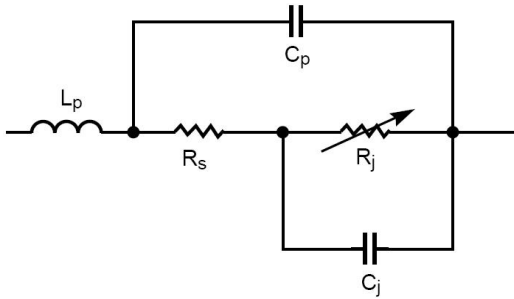

Fig. 4. Equivalent circuit model of diode [27,28].

In Fig. 4, C_j and R_s are the parasitic junction capacitance and series resistance of the diode, respectively. L_p and C_p are the packaging inductance and capacitance respectively. Diode admittance Y_d can be expressed as the following [27]:

$$Y_d = \left(\frac{-jR_j \frac{I}{\omega C_j}}{R_j - \frac{I}{\omega C_j}} + R_s + j\omega L_p \right)^{-1} + j\omega C_p. \quad (4)$$

R_j is the junction resistance of the diode, and expressed as the following [28]:

$$R_j = \frac{8.33 \times 10^{-5} nT}{I_s + I_B}, \quad (5)$$

where I_s is the diode's saturation current, I_B externally applied bias current, T is temperature ($^{\circ}\text{K}$) and n is ideality factor.

As seen in Equation (5), the saturation current is an important parameter for diode impedance. Because of the saturation current, diode impedance varies substantially with the increase of frequency [29]. In these diodes, if the input power level exceeds -15 dBm, the impedance (especially real part) increases rapidly [30]. This situation causes a decrease in the efficiency for these input power levels.

Figures 5 (a) and 5 (b) show the real and imaginary parts of the load impedance values depending on the number of stages for three different individual RF energy harvesters. Due to the effects of both the diode junction surfaces and the capacitors used in stages, the load impedance shows the capacitive feature. As seen from Figs. 5 (a) and 5 (b), as the number of stage increases, the load impedance decreases. This means that an incline in the capacitor value to be used in matching circuit and a decline in inductor value with the increasing of stage number.

As seen in Figs. 5 (a) and 5 (b), the value of load impedance decreases by the input frequency. This provides a reduction for the values of the circuit's

components used in impedance matching circuit. However, the number of diodes and capacitors will increase with the increasing number of stages, this is an undesirable case in terms of both cost and size. Therefore, the high number of stages should be avoided unless it won't provide a large increase in the efficiency.

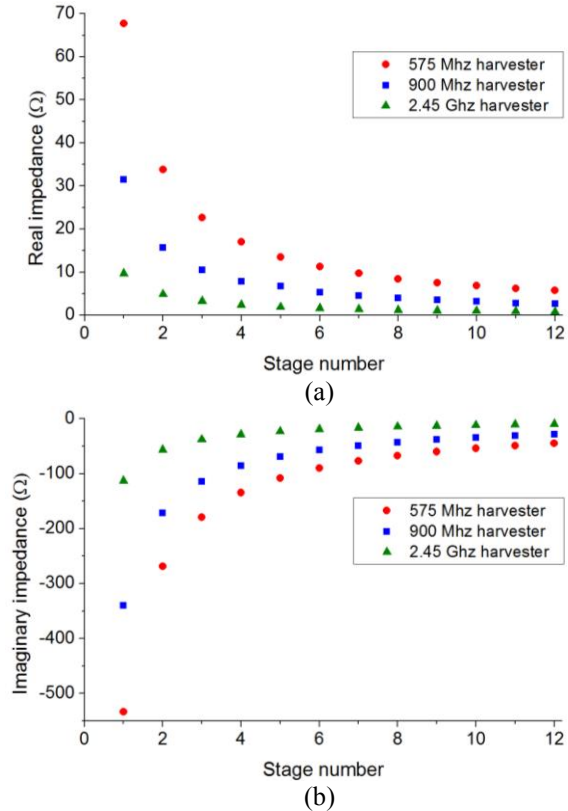

Fig. 5. (a) Real and (b) imaginary parts of the load impedance depending on the number of stages for three different individual RF energy harvesters at 0 dBm.

III. SIMULATION RESULTS

The simulations of the system have been carried out with the ADS software. Initially, the load impedances have been determined at three different frequencies for each number of stages. Then the required impedance matching circuit parameters have been established by the software. Four different systems including 575 MHz, 900 MHz, 2.45 GHz and triple band RF energy harvesters are used in the simulations. The RF input power varying from -50 to 20 dBm have been applied to the systems for to the load resistances from 0.2 to 60 k Ω . As a consequence of this process, the obtained efficiencies have been determined. This process has been tried for all number of stages from one to twelve. The efficiencies calculated are as follows:

$$\eta = \frac{P_r}{P_i} = \frac{V_r^2 / R_L}{P_i}, \quad (6)$$

where P_r and P_t are the received and transmitted powers, respectively, V_r is the obtained voltage, R_L is the load resistance.

In the RF energy harvester systems, one of the most important parameters affecting the output power is the input RF power level. Figure 6 shows efficiencies of the 900 MHz RF energy harvester from the matched and non-matched systems with one stage voltage multiplier for the input power levels from -50 dBm to 20 dBm. As seen from the figure, the impedance matching circuit usage reduces the system efficiency for the input power levels above 5 dBm. This limit value is about 10 dBm and 0 dBm for 575 MHz and 2.45 GHz RF energy harvesters, respectively. For RF signals below these levels, using IMC causes a significant improvement in the efficiency. For instance, if the impedance matching process is done for -20 dBm input signal, the system efficiency is increased nearly seventy-fold. Thus, the determination of the approximate signal level of the media where the system is used is very important to make an appropriate choice of circuit for such applications. The available RF signal level is very important in order to obtain the maximum power from the system whether the impedance matching circuit is used or not. In these applications, the saturation effect is a critical parameter for the system efficiency. In both of matched and unmatched circuits, because of high frequency, the efficiencies decrease by effect of the saturation at the higher than a specific input power. In addition, the efficiency of the diode rectifier will increase until the reverse breakdown voltage of the diode. If the reverse voltage appears across the diode is greater than breakdown voltage, the diode cannot be efficiently rectifier anymore and the rest of the input power is converted to heat in the diode. This results in the decrease in the output efficiency of the RF harvester.

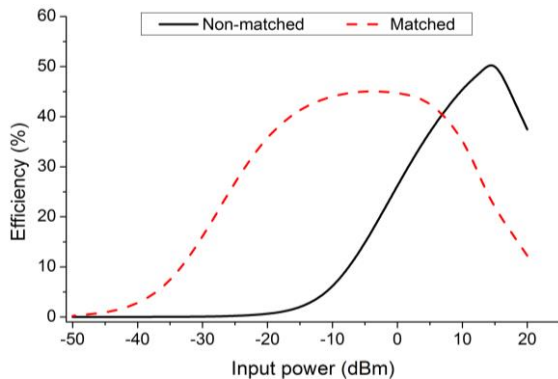

Fig. 6. The efficiency versus the input power for one stage 900 Mhz RF energy harvester.

Figure 7 shows the block diagram of triple band RF energy harvesting system used in this work. As a result of the optimization works, capacitors in the IMCs, which were used for DTV and GSM RF energy harvesters, are deactivated. So the increase in system efficiency is provided and also the cost and the size are decreased. An amount of increase in the values of used inductors has occurred. However, this situation will create any drawback in terms of cost and size.

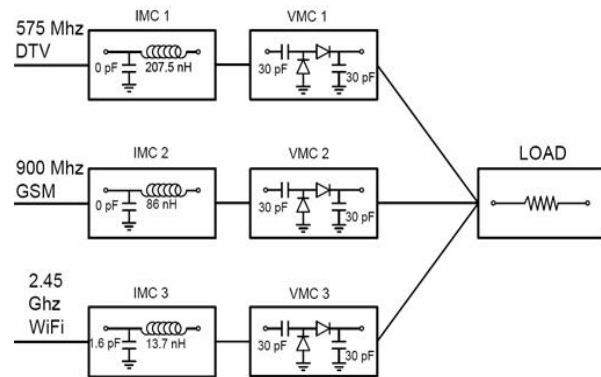

Fig. 7. The block diagram of proposed triple band RF energy harvesting system.

Figure 8 shows the efficiencies of individual DTV (575 MHz), GSM (900 MHz) and WiFi (2.45 GHz) RF energy harvesters depending on the number of the stages at 0 dBm input power. The increase in the input signal frequency decreases the system efficiency because the radiation resistance effects the system at high frequencies. The radiation resistance is directly proportional to the frequency. This resistance has an ohmic effect and causes loss. Therefore, system efficiency is dropped. The system efficiency greatly increases for this input power level as a result of the impedance matching process. But increasing the number of the stage does not cause an increase in the efficiency. As a theoretical rule, if the number of stage in voltage multipliers increases, the obtained voltage is increased, too. But there is not a big increase in the efficiency for higher numbers of stage. Even, there is a decrease in the efficiency. The reason of this situation is the effect of saturation. Considering the effect of saturation, the higher numbers of stage cannot provide a great benefit in every situation. In addition, the system efficiency is dropped the reason of saturation effect at the higher frequencies. Therefore, if the impedance matching circuit is used for this input power, increasing the number of stage is unnecessary. When considered in terms of cost and size, using one stage voltage multiplier is enough.

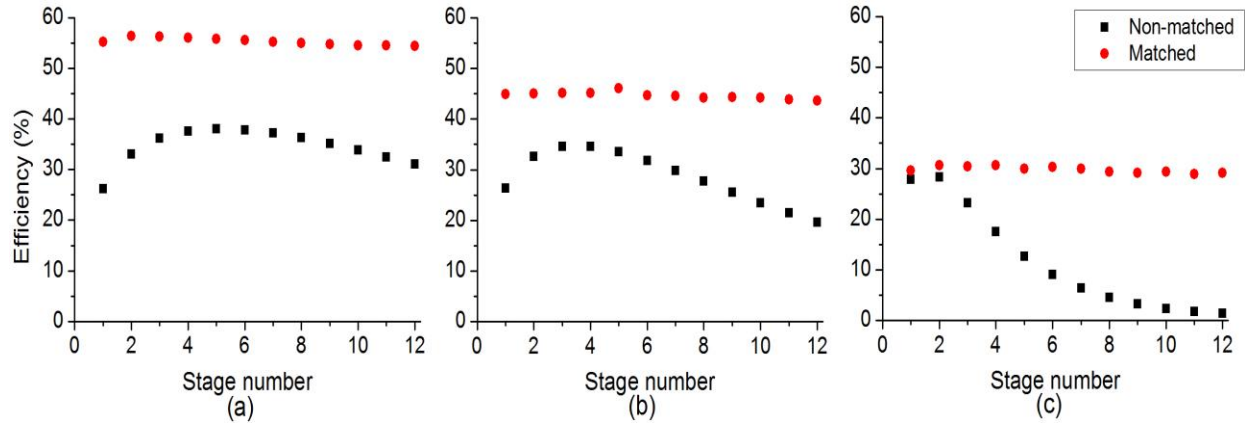

Fig. 8. The efficiency versus the number of the stages for 0 dBm input power: (a) DTV, (b) GSM, and (c) WiFi.

Figure 9 shows the system efficiency of proposed triple band RF energy harvester with one stage voltage multiplier depending on the input RF power level and the load resistance. The system efficiency depends strictly on the input RF power level and the load resistance. The load resistance values which obtained maximum power differ for each RF signal level as shown in Fig. 9. Because the system is optimized according to the 0 dBm input power, the maximum efficiency is obtained from the system while input power is 0 dBm and load resistance is about 6 k Ω . The maximum efficiency is obtained 68% at these values. When the input power level is between -15 dBm and +10 dBm, the system efficiency is realized above 30%. These values are wide range for RF energy harvester systems.

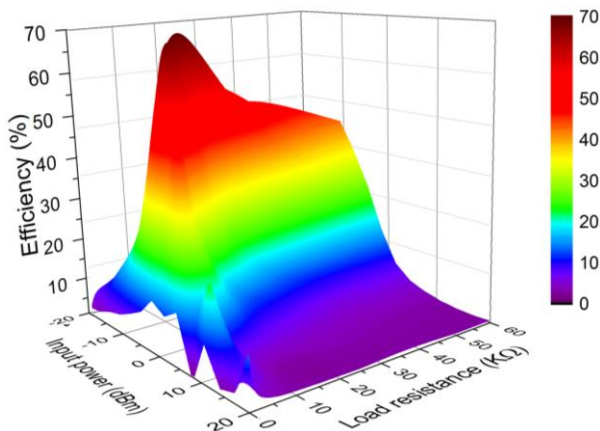

Fig. 9. The efficiency of the proposed system with one stage voltage multiplier depends on the input power and the load resistance.

At the 0 dBm input RF power level, the system efficiency can be obtained as 68% for the load resistance is about 6 k Ω , but this rate decreases to about 20% for 1 k Ω and 20 k Ω . Therefore, accurate determination of the load resistance, connected to the output of RF energy harvester has a great importance. The load impedance cannot be always in these ranges, this problem should be solved via the electronic circuits, which will be connected to the output of the system.

Table 2 shows the obtained powers and the efficiencies at all cases, which three different RF energy harvester have been used individually and one triple band RF energy harvester is used. The system efficiencies are improved significantly with the use of the proposed triple band RF energy harvester. For instance, at 0 dBm input RF power, when the individual DTV, GSM and WiFi RF energy harvesters are used, total obtained power is found to be 1297 μ W; whereas, this value becomes 2045 μ W for the proposed integrated triple band RF energy harvester. This proves that an increase with approximately 58% occurs in the system efficiency.

The proposed triple band RF energy harvester is increased the efficiency also in the environments where only one or two RF signals exist. The system overcomes the problem of the low efficiency for individual systems with high frequencies such as 2.45 GHz. In a media, where only 2.45 GHz RF signal is available, when the proposed triple band RF energy harvester is used instead of individual RF energy harvester, the obtained efficiency from the system increases by approximately 134%. Thus, the proposed new system can be used with high efficiency in both low and high frequencies. The obtained efficiency from the proposed system is realized as 56.70%, even in the case where only the DTV signal is 0dBm input level.

Table 2: The output powers and efficiencies for one stage individual and triple band RF energy harvesters at 0 dBm

			Individual System		Triple Band System		
575 MHz	900 MHz	2.45 GHz	Power (μ W)	Efficiency (%)	Power (μ W)	Efficiency (%)	Difference %
✓	✓	✓	1297	43.27	2045	68.18	+57.57
✓	✓		1000	50.02	1324	66.21	+32.36
✓		✓	848	42.41	1289	64.43	+51.92
	✓	✓	745	37.26	1448	72.42	+94.36
✓			552	55.17	567	56.70	+2.77
	✓		449	44.86	726	72.57	+61.77
		✓	297	29.65	694	69.35	

IV. CONCLUSIONS

The voltage multiplier circuits must be used in RF energy harvester, because obtained voltage is very low in scale. The obtained voltage and the harvested power directly depend on the input RF signal level. The impedance matching process significantly increases the obtained power from the system especially at low levels input RF signals. Therefore, if there are low level input signals for the RF energy harvesting, the impedance matching must be used. But the impedance matching process cannot provide a major contribution to the harvested power at the high levels input RF signals such as 20 dBm. The high levels of input RF signal do not always mean the high efficiency. In this work, the maximum efficiency has been obtained in the case, which the input signal is 0 dBm. With the use of proposed triple band RF energy harvester, the efficiency is increased by 58% compared to the conventional individual systems having three different frequencies. Furthermore, the system is increased the efficiency significantly also in environments, where only one or two RF signals exist.

REFERENCES

- [1] H. Jabbar, Y. S. Song, and T. T. Jeong, "RF energy harvesting system and circuits for charging of mobile devices," *IEEE Trans. on Consumer Electron.*, vol. 56, no. 1, pp. 247-253, Feb. 2010.
- [2] A. Rahimi, O. Zorlu, A. Muhtaroglu, and H. Kulah, "An electromagnetic energy harvesting system for low frequency applications with a passive interface ASIC in standard CMOS," *Sensor Actuat. A-Phys.*, vol. 188, pp. 158-166, Dec. 2012.
- [3] Z. W. Sim, R. Shuttleworth, M. J. Alexander, and B. D. Grieve, "Compact patch antenna design for outdoor RF energy harvesting in wireless sensor networks," *Prog. Electromagn. Res.*, vol. 105, pp. 273-294, June 2010.
- [4] K. Chang, S. Kang, K. Park, S. Shin, H. S. Kim, and H. Kim, "Electric field energy harvesting powered wireless sensors for smart grid," *J. Electrical Eng. & Tech.*, vol. 7, no. 1, pp. 75-80, Jan. 2012.g
- [5] Y. Uzun, S. Demirbas, and E. Kurt, "Implementation of a new contactless piezoelectric wind energy harvester to a wireless weather station," *Elektron Elektrotech.*, vol. 20, no. 10, pp. 35-39, 2014.
- [6] M. L. Sichitiu and R. Dutta, "On the lifetime of large wireless sensor networks with multiple battery levels," *Ad Hoc Sens. Wirel.*, vol. 4, no. 1-2, pp. 69-96, 2007.
- [7] K. Eguchi, K. Fujimoto, and H. Sasaki, "A hybrid input charge-pump using micropower thermoelectric generators," *IEEJ T. Electr. Electr.*, vol. 7, no. 4, pp. 415-422, 2012.
- [8] U. Alvarado, A. Juanicorena, I. Adin, B. Sedano, I. Gutiérrez, and J. de N6, "Energy harvesting technologies for low-power electronics," *T. Emerg. Telecommun. T.*, vol. 23, no. 8, pp. 728-741, 2012.
- [9] T. Wu and H. C. Yang, "On the performance of overlaid wireless sensor transmission with RF energy harvesting," *IEEE J. Sel. Area Comm.*, vol. 33, no. 9, pp. 1-12, 2015.
- [10] S. Sudevalayam and P. Kulkarni, "Energy harvesting sensor nodes: survey and implications," *Commun. Surveys Tuts.*, vol. 13, no. 3, pp. 443-461, 2011.
- [11] Y. Uzun and E. Kurt, "The effect of periodic magnetic force on a piezoelectric energy harvester," *Sensor Actuat. A-Phys.*, vol. 192, pp. 58-68, 2013.
- [12] U. Olgun, C. C. Chen, and J. L. Volakis, "Design of an efficient ambient WiFi energy harvesting system," *IET Microw. Antenna P.*, vol. 6, no. 11, pp. 1200-1206, 2012.
- [13] L. Guenda, E. Santana, A. Collado, K. Niotaki, N. B. Carvalho, and A. Georgiadis, "Electromagnetic energy harvesting-global information database," *Trans. Emerg. Telecom. Tech.*, vol. 25, no. 1, pp. 56-63, 2014.
- [14] A. Costanzo, A. Romani, D. Masotti, N. Arbizzani, and V. Rizzoli, "RF/baseband co-design of switching receivers for multiband microwave energy harvesting," *Sensor Actuat. A-Phys.*, vol. 179, pp. 158-168, June 2012.
- [15] D. Masotti, A. Costanzo, M. D. Prete, and V. Rizzoli, "Genetic-based design of a tetra-band high-efficiency radio-frequency energy harvesting

- system,” *IET Microw. Antenna P.*, vol. 7, no. 15, pp. 1254-1263, 2013.
- [16] D. Bouchouicha, F. Dupont, M. Latrach, and L. Ventura, “Ambient RF energy harvesting,” *Int. Conf. on Renewable Energies and Power Quality*, Granada, Spain, pp. 1-5, Mar. 2010.
- [17] R. Shigeta, T. Sasaki, D. M. Quan, Y. Kawahara, R. Vyas, M. Tentzeris, and T. Asami, “Ambient-RF-energy-harvesting sensor node with capacitor-leakage-aware duty cycle control,” *IEEE Sensors J.*, vol. 13, pp. 2973-2983, 2013.
- [18] L. Xiao, W. Ping, D. Niyato, and E. Hossain, “Dynamic spectrum access in cognitive radio networks with RF energy harvesting,” *IEEE Wirel. Commun.*, vol. 21, no. 3, pp. 102-110, 2014.
- [19] K. Xie, Y. M. Liu, H. L. Zhang, and L. Z. Fu, “Harvest the ambient AM broadcast radio energy for wireless sensors,” *J. Electromagnet. Wave.*, vol. 25, pp. 2054-2065, 2011.
- [20] N. M. Din, C. K. Chakrabarty, A. B. Ismail, K. A. Devi, and W. Y. Chen, “Design of RF energy harvesting system for energizing low power devices,” *Prog. Electromagn. Res.*, vol. 132, pp. 49-69, 2012.
- [21] C. Wanga, M. Park, W. Zhao, G. Liu, Z. Dilli, and M. Peckerar, “An ultra-low power regulator system for WSNs powered by energy harvesting,” *Solid State Electron.*, vol. 101, pp. 38-43, 2014.
- [22] B. L. Pham and A. V. Pham, “Triple bands antenna and high efficiency rectifier design for RF energy harvesting at 900, 1900 and 2400 MHz,” *IEEE MTT-S International Microwave Symposium Digest*, Seattle, USA, pp. 1-3, June 2013.
- [23] S. Keyrouz, H. J. Visser, and A. G. Tjhhuis, “Multi-band simultaneous radio frequency energy harvesting,” *7th European Conference on Antennas and Propagation*, Gothenburg, Sweden, pp. 3058-3061, Apr. 2013.
- [24] P. Kim, G. Chaudhary, and Y. Jeon, “A dual-band RF energy harvesting using frequency limited dual-band impedance matching,” *Prog. Electromagn. Res.*, vol. 141, pp. 443-461, 2013.
- [25] D. M. Pozar, *Microwave Engineering*, John Wiley & Sons, Inc., USA, 2011.
- [26] P. Nintanavongsa, U. Muncuk, D. R. Lewis, and K. R. Chowdhury, “Design optimization and implementation for RF energy harvesting circuits,” *IEEE Trans. Emerg. Sel. Topics Circuits Syst.*, vol. 2, no. 1, pp. 24-33, 2012.
- [27] A. Nimo, T. Beckedahl, T. Ostertag, and L. Reindl, “Analysis of passive RF-DC power rectification and harvesting wireless RF energy for micro-watt sensors,” *AIMS Energy*, vol. 3, no. 2, pp. 184-200, 2015.
- [28] HSMS-285x Series, *Surface Mount Zero Bias Schottky Detector Diodes*, Datasheet, Avago Tech., 2009.
- [29] A. Nimo, J. Albesa, and L. M. Reindl, “Investigating the effects of parasitic components on wireless RF energy harvesting,” *11th Int. Conf. on Multi-Conference on Systems, Signals & Devices*, Barcelona, Spain, pp. 1-6, Feb. 2014.
- [30] H. J. Visser, V. Pop, B. O. H. Veld, and R. J. M. Vullers, “Remote RF battery charging,” *Proceedings of Power MEMS 2010*, Leuven, Belgium, pp. 37-40, Dec. 2010.



Yunus Uzun received his B.S., M.Sc. and Ph.D. degrees from the Gazi University in 2000, 2004 and 2012, respectively. He worked as a High School Teacher on electrics from his graduation to 2008. He was a Lecturer in the Department of Electrics and Energy of Ahi Evran University for 6 years. Then he was assigned to the Assist. Prof. Dr. position in the Dept. Electrical and Electronics Engineering of Aksaray University in 2014. His main research area focuses on the experimental and theoretical explorations of energy harvesting systems.