

## Wearable Graphene Based Curved Patch Antenna for Medical Telemetry Applications

**Rajni Bala<sup>1</sup>, Rajdeep Singh<sup>1</sup>, Anupma Marwaha<sup>1</sup>, and Sanjay Marwaha<sup>2</sup>**

<sup>1</sup> Department of Electronics & Communication Engineering

<sup>2</sup> Department of Electrical and Instrumentation Engineering

SLIET Longowal, Punjab, 148106, India

rajnisliet@gmail.com, rajdeep.sliet91@gmail.com, marwaha\_anupma@yahoo.co.in, marwaha\_sanjay@yahoo.co.in

**Abstract** — In order to explore the expediency of graphene for biotelemetry in Wireless Body Area Network (WBAN), conformal square patch antenna design has been presented in this paper. The operational efficiency of the antenna is attributed to the incredible properties of graphene as patch conductor. The proposed antenna designed for operating in band from 1-4.88 GHz is fed with microstrip line and quarter wave transformer for impedance matching. The antenna however achieves best performance at 2.4 GHz in ISM band with good impedance matching, reasonable dB gain and high radiation efficiency for the wideband of frequencies in GHz range. The proposed wearable conformal graphene based antenna is optimally positioned at distance from body to make it suitable for Ultra Wide Band (UWB) health monitoring systems fulfilling the requirements of wideband operation, high gain and improved radiation efficiency at reduced SAR.

**Index Terms** — Biotelemetry, CST, curved patch antenna, graphene, WBAN.

### I. INTRODUCTION

A WBAN consists of wireless nodes located on body which may communicate with each other and/or with an external base station using an efficient antenna. When body area network communicates with external base station, it is known as off-body communication. In biotelemetry applications more concentration is on off body communication. It is similar to mobile phone network, where mobile is in human proximity communicates with base station at distant place. The different antennas that have been used for body area networks include monopole Microstrip Patch Antenna (MPA) [1] and dipole microstrip patch antenna [2]. It is well documented that for telemetry applications the antenna should have small size high directivity, small Specific Absorption Ratio (SAR), circular polarization and should consume less power because it is not easy to carry a large battery with antenna [3-4]. Subhashini et al. observed that when inset feed MPA is placed 10 mm

above the body phantom, the maximum SAR (10g) is 0.0190563 W/kg. Further the gain of antenna reduces when it is attached to the body phantom [5-6]. Kwon et al. showed that if the patch antenna is placed on body with given input power of 250 mW then maximum SAR value is 0.455 W/kg [4]. In order to flexibly place the antenna on any part of body including arm or wrist, it is desirable that the antenna should be curved along a cylindrical surface of desired radius. But as the radius changes, hence the curvature of body surface changes the performance parameters of antenna undergo variations. The radiation characteristics also depend upon radius of curvature [7]. It is desirable that the performance of the antenna should not be deteriorated on account of variations in radiation characteristics. The curved antenna designed here utilizes graphene as patch conductor to allow easy control of various parameters including resonant frequency, bandwidth on account of tunable surface conductivity on the basis of varying the chemical potential or the applied DC bias [8-9]. Moreover, the conductivity of graphene is highly frequency-dependent and the designed antenna can therefore possess completely different behavior. The constraints however for operating the planar graphene antenna in GHz range are the poor radiation efficiency and limited bandwidth [4]. The proposed square patch antenna is stretched to give curvature hence conforming to curved parts of body. The curved patch antenna also overcomes the drawback of limited radiation efficiency as the cylindrical structures offer better radiation efficiency performance than their planar counterparts [8]. The bandwidth can also be increased with increase in curvature [10]. Due the different curvatures of body parts for different persons the designed antenna with given dimensions may undergo up to 0.2% variation in resonant frequency [7]. In order to accommodate for these variations the proposed wearable antenna is designed to exhibit good resonant and radiation characteristics for operating band of 1-4.88 GHz. The microstrip line fed graphene based curved patch antenna designed on silicon substrate with dielectric constant

$\epsilon_r = 11.9$  will prove to be useful to provide telemetry services for health monitoring systems in WBAN applications.

## II. GRAPHENE MODELING

The radiation and absorption characteristics of graphene as patch conductor depend on the modeling of graphene conductivity coupled with Maxwell's equations. An infinitesimally thin layer of graphene sheet is modeled using the surface conductivity as derived from the Kubo's formula [11]. It has been noticed that in the low frequency range the inter band contributions of graphene conductivity can be ignored [12] and hence, the surface conductivity can be expressed by using only intraband contributions as:

$$\sigma = -j \frac{q_e^2 k_B T}{\pi \hbar^2 (\omega - j2\Gamma)} \left[ \frac{\mu_c}{k_B T} + 2 \ln \left( e^{-\frac{\mu_c}{k_B T}} + 1 \right) \right], \quad (1)$$

where  $\omega$  is the angular frequency,  $k_B$  is the Boltzmann's constant,  $\hbar$  is the reduced Planck constant,  $q_e$  is the electron charge,  $T$  is temperature, and  $\mu_c$  is graphene chemical potential,  $\Gamma$  is electron scattering rate expressed in terms of relaxation time as  $\tau = 1/2\Gamma$ . In this work, the modeling of graphene material as patch is performed on CST (Computer Simulation Technology) 2014 commercial package with CST microwave studio [13] with help of macro program which permits the inclusion of graphene material characterized by appropriate physical, thermal and electrical properties. The present analysis is carried out at room temperature  $T = 300$  °K,  $\tau = 1$  ps, and  $\mu_c$  is kept below 1 eV in order to obtain sufficient radiation efficiency [14]. The various properties of graphene material considered for designing patch antenna are presented in Table 1.

Table 1: Electrical and non-electronic mechanical properties of graphene material

Parameter	Graphene Material Parameter Value
Dielectric loss tangent	0.077 [15]
Material density	2250 Kg/m <sup>3</sup>
Heat capacity	2100 KJ/k/kg
Thermal conductivity	5000 W/mk [16]
Thermal diffusivity	1.0582×10 <sup>-6</sup> m <sup>2</sup> /s
Breaking strength	40 N/m [17-18]
Young's modulus	1000 GPa [18]
Poisson's ratio	0.17 [18]
Thermal expansion coefficient	17.7×10 <sup>-6</sup> /K

## III. DESIGN OF GRAPHENE BASED CURVED PATCH ANTENNA

The graphene based curved patch antenna designed to resonate at 2.4 GHz is mounted on three layer cylindrical body phantom as shown in Fig. 1, keeping in view the installation of antenna flexibly on any curved parts of human body including arms and legs. The

antenna can be oriented conforming to body in two ways either lengthwise or widthwise. When antenna is curved lengthwise along the width, there will be expansion in length due to stretching therefore affecting the fringing fields. The increased length is then required to be calculated as a function of angle of curvature [19]. Further, when the curved antenna is positioned along the length, the antenna gets curved widthwise; hence, increasing the width of patch due to stretching which will not effectively vary the resonant frequency. Conventionally, the width variations doesn't affect the resonant frequency however variations in frequency are still observed with curvature because due to stretching and compression in materials at different positions dielectric constant of material further changes and dielectric constant is inversely proportional to frequency.

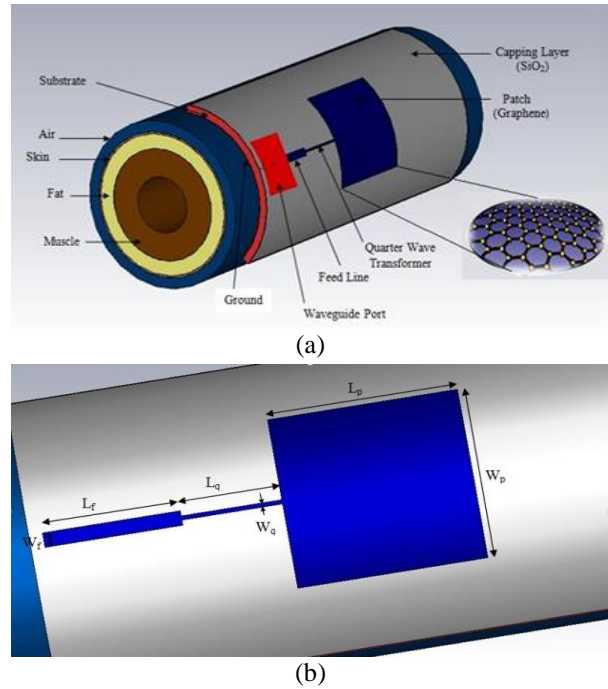

Fig. 1. (a) Graphene based curved patch antenna model, and (b) dimensional view.

For a flat rectangular microstrip patch antenna, the resonance frequency for any  $TM_{mn}$  mode is given by James and Hall [20] consisting of  $m$  and  $n$  are modes along length of patch ( $L_p$ ) and width of patch ( $W_p$ ) respectively. Bahl and Bhartia [21] defined the width  $W_p$  for efficient radiation as given below:

$$W_p = c / (2 * \frac{f * \sqrt{\epsilon_r + 1}}{\sqrt{2}}), \quad (2)$$

where  $c$  is velocity of light,  $f$  is resonant frequency and  $\epsilon_r$  is the dielectric constant of the substrate. Due to the air-dielectric interface, effective dielectric constant ( $\epsilon_{r\text{eff}}$ ) can be calculated as the combination of dielectric constant of substrate and dielectric constant of air above

it at the edges of the patch in order to account for the fringing fields around the periphery of the patch as given by [21]:

$$\epsilon_{\text{reff}} = \frac{\epsilon_r + 1}{2} + \frac{\epsilon_r - 1}{2} / \sqrt{[1 + 12 * \frac{h}{W_p}]}, \quad (3)$$

where  $h$  is the height of substrate. Due to effect of fringing length of patch looks electrically wider than its physical length. Now actual length of patch can be calculated as the function of effective dielectric constant as:

$$L_p = \left\{ \left[ \frac{c}{2 * f * \sqrt{\epsilon_{\text{reff}}}} \right] - 2 \left[ 0.412h * \frac{(\epsilon_{\text{reff}} + 0.3) * (\frac{W_p}{h} - 0.264)}{(\epsilon_{\text{reff}} - 0.258) * (\frac{W_p}{h} - 0.8)} \right] \right\}. \quad (4)$$

When the curved patch antenna is placed lengthwise, the length becomes stretched due to curvature and if the amount of curvature is  $\theta$ , then actual length of patch required to resonate at same frequency will get reduced by a factor  $\left[ h * \frac{\theta}{2} \right]$  and the specific length of patch required will then be given by:

$$L_p = \left\{ \left[ \frac{c}{2 * f * \sqrt{\epsilon_{\text{reff}}}} \right] - \left[ h * \frac{\theta}{2} \right] - 2 \left[ 0.412 * h * \frac{(\epsilon_{\text{reff}} + 0.3) * (\frac{W_p}{h} - 0.264)}{(\epsilon_{\text{reff}} - 0.258) * (\frac{W_p}{h} - 0.8)} \right] \right\}. \quad (5)$$

The effect of curvature on resonant frequency has been presented by Krowne [3] as:

$$f_{mn} = \frac{1}{2\sqrt{\mu\epsilon_r}} \sqrt{\left(\frac{m}{\theta r}\right)^2 + \left(\frac{n}{L_p}\right)^2}, \quad (6)$$

where  $r$  is radius of the curvature,  $\theta$  is the angle bounded the width of the patch,  $\epsilon_r$  is dielectric constant and  $\mu$  is the magnetic permeability.

In the present case the curved antenna is placed widthwise so there will be no effect on length. Further, the proposed curved antenna uses graphene material as patch which supports Transverse Magnetic (TM) Surface Plasmon Polaritons (SPP) waves with an effective mode index given by [22-23]:

$$\eta_{eff}(\omega) = \sqrt{1 - \frac{4\mu_0}{\epsilon_0\sigma(\omega)^2}}. \quad (7)$$

The resonant behavior in graphene is therefore achieved due to the coupling of electromagnetic radiations with the SPP waves. The length of patch for the curved graphene patch antenna is thus based on the resonant conditions for graphene as given by:

$$m \frac{1}{2} \frac{\lambda}{\eta_{eff}} = L_p + 2\delta L, \quad (8)$$

where  $m$  is an integer determining the order of the resonance,  $\lambda$  is the wavelength of the incident radiation,  $L_p$  is the antenna length and  $\delta L$  is a measure of the field penetration outside the graphene-based patch antenna.

The graphene based curved patch antenna is designed as a four layer structure where at the bottom

layer is ground plane of perfect electrical conductor (PEC), highly conducting material. The next layer is the high permittivity silicon (Si) substrate with dielectric constant,  $\epsilon_r = 11.9$  followed by a lower permittivity silicon dioxide (SiO<sub>2</sub>) capping layer. The fourth layer situated on the top is the graphene patch radiator. The purpose of capping layer is to provide good optical contrast facilitating the visibility of even single graphene layer [24]. The antenna is edge fed by a microstrip line and quarter wave transformer for further impedance matching.

The dimensional parameters are selected to operate the designed antenna in the frequency range of 1-4.88 GHz as described in Table 2. The operating band includes the resonant frequency of 2.4 GHz that comes under the Industrial Scientific and Medical (ISM) band which is the approved frequency band for on body antennas according to Federal Communications Commission (FCC). The simulation analysis has been carried out with CST software based on finite integral technique. The software operates with automatic optimization tools utilizing transient solver for analyzing curved antenna structures with lossy and anisotropic material properties. CST software further supports coupled bio-electromagnetic problems and suitable for determining the absorption effects of radiations on human body.

Table 2: Dimensions of graphene curved patch antenna

Parameter	Value
Operating frequency band	1-4.88 GHz
Substrate length and width	(75.4×68) mm
Silicon ( $\epsilon_r = 11.9$ ) substrate height	2.5 mm
Length, width of curved patch ( $L_p \times W_p$ )	(35×35) mm
Patch thickness	10 nm
Height of capping layer SiO <sub>2</sub> ( $\epsilon_r = 3.8$ )	1000 nm
Length, width of feed ( $L_f \times W_f$ )	(17.8×2.9) mm
Length, width of $\lambda/4$ transformer ( $L_q \times W_q$ )	(10.9×0.79) mm
Radius of curvature for antenna	30 mm

The entire graphene based curved patch antenna is placed on cylindrical body phantom of length 160 mm for analyzing the effect of radiation characteristics on the human body. The body phantom considered here consists of three cylindrical layers. The outer layer represents skin, middle layer being the fat layer and innermost layer is for muscle with the respective physical and dielectric properties as given in Table 3. The dimensions of body phantom layers can vary from person to person. Here the dimensions of different layers of body phantom for an average healthy person have been considered.

Table 3: Parameters of the body tissues at 2.4 GHz

Body Tissue of Length 160 mm	Skin (Dry)	Fat	Muscle
Thickness (mm)	0.65	5.25	10
Conductivity(s/m) [25]	1.464	0.10452	1.7388
Permittivity [20-21]	38.007	5.2801	52.729

#### IV. SIMULATION RESULTS

The curved shape antenna is designed with an objective to place the antenna conforming to curved body parts to facilitate health telemetry services at 2.4 GHz in ISM band for wireless communication networking. The careful examination of return loss, VSWR, gain, directivity, SAR and radiation characteristics is essential for performance evaluation of the antenna. The reference power is set at 1W for the operation at the resonant frequency. The wide operating band is obtained for the curved graphene antenna as is visible from the return loss plot given in Fig. 2. The return loss less than -10 dB show that the antennas are very well matched to the impedance transformer. It is evident from the plot that return loss  $S_{11}$  maintains less than -10 dB value in the operating band from 1-4.88 GHz. The value of  $S_{11}$  reaches a minimum value of -25.04 dB at resonating frequency of 2.4 GHz and -25.17 dB at resonating frequency of 3.94 GHz.

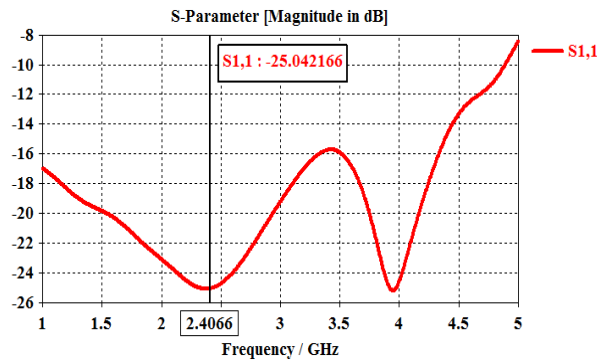

Fig. 2. Return loss versus frequency.

If the antenna impedance is matched to the transmission line at resonance, the mismatch off resonance is related to the voltage standing wave ratio. The value of VSWR which can be tolerated then defines the bandwidth of the antenna. The VSWR values of 1.118 and 1.12 are achieved at the respective resonating frequencies 2.4 GHz and 3.94 GHz as shown in Fig. 3.

In order to study the effect of curvature on the antenna performance, the radius of curvature is varied from 25 mm to 35 mm with an incremental step of 2 mm. As seen from Fig. 1, the curved graphene patch antenna is positioned widthwise along the length of body part so conventionally the variation in curvature will result in only minor variations in resonant frequency. However

for graphene patch antennas it has been observed that increase in width of patch results in shifting of resonant frequency to higher side [22-23]. The variation in resonant frequency with curvature for the proposed graphene patch antenna is plotted in Fig. 4. The plot doesn't seem to follow any particular trend on account of increased width but the optimum resonant behavior is apparent for radius of curvature as 30 mm. For conformal antennas the analytical justification to determine the effect of curvature on resonant characteristics for graphene patch is yet to be explored.

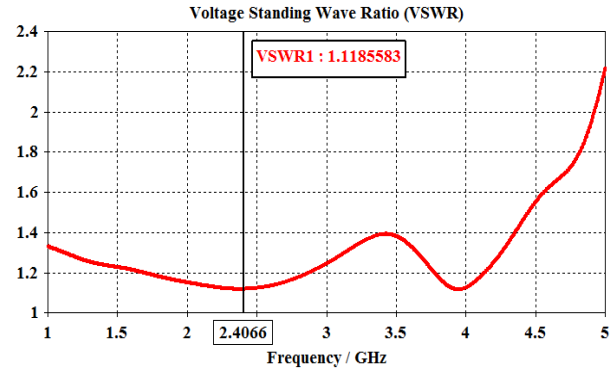

Fig. 3. VSWR versus frequency.

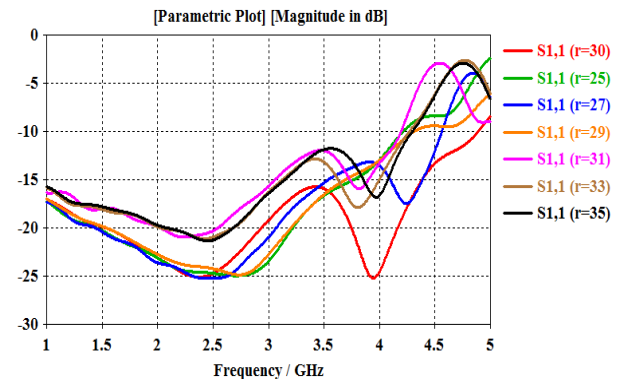

Fig. 4. Variation in resonant frequency with curvature.

The radiation efficiency of planar graphene patch antenna is deteriorated due to excessive absorption losses in GHz range. The radiation efficiency capabilities can however be compensated by using silicon substrate material with higher dielectric constant. The further improvement in radiation efficiency is obtained as compared to planar structure due to curvature. Figure 5 shows that the radiation efficiency achieved for the antenna is about 79.09% at resonating frequency of 2.4 GHz and drops down to 74.86% at resonating frequency of 3.94 GHz.

Figure 6 depicts that the peak gain attains value more than 5 dB for a very wide range of frequencies which is reasonably good for design of graphene curved

patch antenna for biotelemetry applications. The obtained gain is 10.19 dB at the desired frequency of 2.4 GHz and 2.8 dB at the second resonant frequency of 3.94 GHz.

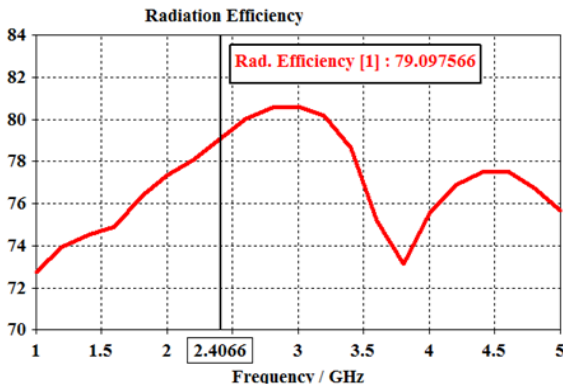

Fig. 5. Radiation efficiency (in %) versus frequency.

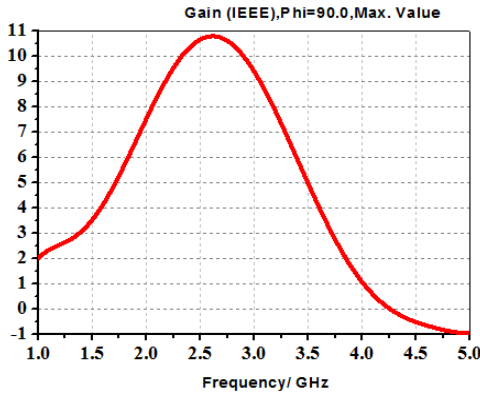

Fig. 6. 2D gain (in dB) as function of frequency.

The 3D radiation patterns for gain and directivity at 2.4 GHz are as plotted in Fig. 7. The simulated far field radiation patterns for dB gain in the azimuth plane for  $\phi = 0^\circ$  and  $90^\circ$  at 2.4 GHz for the graphene curved patch antenna are shown in Fig. 8, the symmetry and wide angular radiation patterns are observed. The proposed antenna offers the benefit of providing wide operating band hence facilitating its utility not only for short-range, high-data-rate communication ISM band but it also suits for UWB WBAN at 4-7 GHz in applications with human bodies. It can be made to resonate at multiple frequencies on account of inherent property of tunability of graphene material. The graphene based curved patch antenna built on silicon substrate ( $\epsilon_r = 11.9$ ) interestingly obtains multi resonant characteristics with simple design without resorting to complex methods of slot loading or texturing the patches by slits, stacked patches, extra microstrip resonators, additional parasitic patches as done by other researchers [4], [25-26].

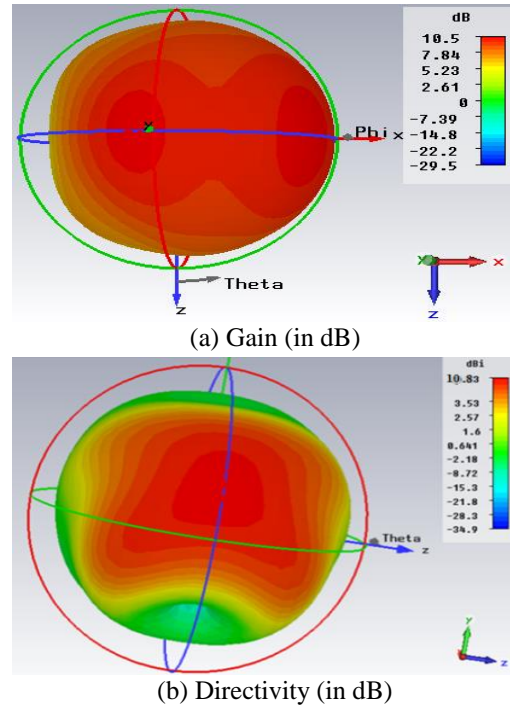

Fig. 7. 3D polar plots.

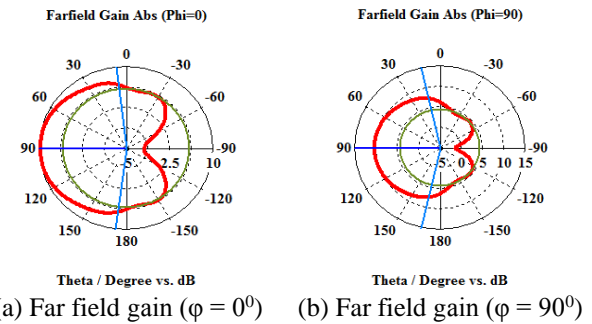

Fig. 8. Simulated radiation patterns of the graphene curved patch antenna.

Without air gap high permittivity of body tissues will absorb maximum amount of radiations which will have dangerous effect on body tissues. Further it also results in reducing the gain to a very low value. As the air gap increases antenna gain increases and SAR decreases. Figure 9 shows the measured SAR distributions of the graphene based curved patch antenna located on the human body phantom model. Since the wearable antennas are to be placed close to or even in contact with the human body, it is important that the level of electromagnetic radiation does not exceed the official recommendations. The present antenna design results in the maximum SAR value of 0.000148 W/Kg at 2.4 GHz calculated for an average mass of 10g of tissue which is

well below the specified limits [27].

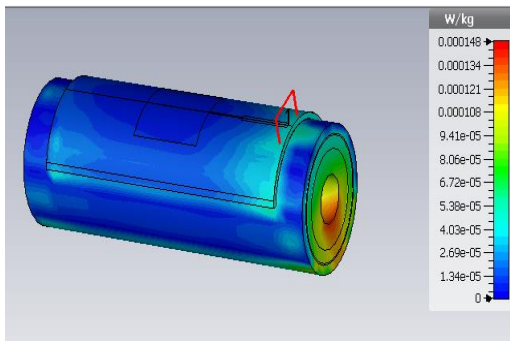

Fig. 9. SAR distribution at 2.4 GHz.

The SAR is an essential factor to be considered when the antenna is operated on or inside the body and to circumvent the absorption of the electromagnetic radiations emitted by the antenna by human body in WBAN, SAR value must be minimized. The SAR distribution is effected by the antenna parameters including its distance from body, radiation power and antenna type. The SAR value being influenced by the position of antenna from body, the antenna installation is done on the body keeping an air gap of 4 mm.

It has been observed that researchers are designing conformal antennas for wearable applications without

analyzing the effect of radiated power from the antenna on human body.

Sankaralingam et al. have designed wearable textile antennas using different values of dielectric constant of fabric substrate materials and simulative analysis is performed using IE3D simulator based on Method of Moments (MoM) for GHz radiations [28]. All the results are presented for free space conditions ignoring the effects on body interaction. Moreover the gain and radiation efficiency achieved is more for the proposed graphene antenna. Much improvement in fractional bandwidth is also evident from Fig. 2. Huang et al. have designed printed graphene antenna on paper substrate and proved in their work that RF signal can be effectively radiated and received by the graphene antennas [29]. The experimental demonstration assures the potential use of graphene antenna in wireless wearable communications systems covering the bands for Wi-Fi, Bluetooth and WLAN by presenting a real life scenario. But the absorption effects of the antenna radiations on the human body have not been considered whereas the proposed antenna satisfies the permissible SAR limits. Overall the conformal graphene antenna performs well with enhanced gain of 10.19 dB at resonant frequency of 2.4 GHz and the maximum radiation efficiency constantly remains greater than 72% for the wideband of frequencies in 1-5 GHz range. The detailed comparative analysis performed is presented in Table 4.

Table 4: Comparison of proposed antenna with metallic patch antenna and other graphene antennas

Parameters		Proposed Design	Sankaralingam et al. [28]	Kwon et al. [4]	Huang et al. [29]
Material	Patch	Graphene	Copper	Copper	Graphene
	Substrate	Silicon with capping layer of SiO <sub>2</sub>	Varieties of cotton and polyester	FR-4	Paper
Return Loss (S <sub>11</sub> , dB)		-25.05 dB at 2.4 GHz -25.17 dB at 3.94 GHz	-28.5 at 2.44 GHz	-15 dB at 403.5 MHz -28.5 dB at 2.45 GHz	-18.7 dB at 1.97 GHz -19.2 dB at 3.26 GHz
Gain		10.5 dB at 2.4 GHz 2.8 dB at 3.94 GHz	7.730 dB	-31.98 dB at 403.5 MHz 0.24dB at 2.45 GHz	0.2 dB at 1.97 GHz -1dB at 3.26 GHz
Directivity		10.83 dB at 2.4 GHz	8.750 dB	Not evaluated	Not evaluated
VSWR value		1.118 at 2.4 GHz 1.12 at 3.94 GHz	Not evaluated	Not evaluated	Not evaluated
Radiation efficiency (%)		79.09 at 2.4 GHz 74.86 at 3.94 GHz	79.20 dB	Not evaluated	Not evaluated
Bandwidth		3.88 GHz	87.31 MHz	15 MHz at 403.5 MHz 91 MHz at 2.45 GHz	1.29 GHz
SAR (W/Kg)		0.000148	Not evaluated	0.0087 at 403.5 MHz 0.0081 at 2.45 GHz	Not evaluated

## V. CONCLUSION

In this paper the utility of graphene is investigated for designing curved patch antenna for flexible handy wireless body area network applications. An attempt has been made to examine the effect of radius of curvature

on the resonant frequency which can be compensated by graphene tunability. The antenna however provides sufficient bandwidth to accommodate for the variations in resonant frequency.

The microstrip line edge fed graphene based curved

square patch antenna achieves acceptable radiation efficiency with minimum SAR in the operating range of 1-4.88 GHz. Quarter wave transformer is used for optimizing the resonant properties hence obtaining return loss of -25.05 dB at resonating frequency of 2.4 GHz and -25.17 dB at second resonating frequency of 3.94 GHz. FIT based CST microwave studio simulation software is used for graphene characterization and numerical modeling of the designed antenna. Owing to the tunability feature of graphene, the simple curved square patch antenna achieves wideband operation and is therefore suitable for UWB biotelemetry WBAN applications.

### ACKNOWLEDGMENT

This work is supported by Department of Electronics and Communication Engineering of Sant Longowal Institute of Engineering and Technology, Longowal, Punjab, by providing software facilities such as HFSS, Matlab and other computational material.

### REFERENCES

- [1] S. Kumari and V. R. Gupta, "Measurement of specific absorption rate of monopole patch antenna on human arm," *International Journal Microwave Optical Technology*, vol. 10, pp. 190-194, 2015.
- [2] N. A. Elias, N. A. Samsuri, M. K. A. Rahim, and N. Othman, "The effects of human body and bending on dipole textile antenna performance and SAR," *Microwave Conference Proceeding (APMC) Asia-Pacific Kaohsiung, Taiwan, 2012*, E-ISBN: 978-1-4577-1331-6, pp. 34-36, 2012.
- [3] C. M. Krowne, "Cylindrical-rectangular microstrip antenna," *IEEE Transactions Antenna Propagation*, vol. 31, pp. 194-199, 1983.
- [4] K. Kwon, J. Ha, S. Lee, and J. Choi, "Design of a dual-band on-body antenna for a wireless body area network repeater system," *International Journal Antenna Propagation*, pp. 1-5, 2012.
- [5] A. Subhashini, "Design of microstrip patch antenna used in wireless body area network (WBAN)," *International Journal Scientific Research Development*, vol. 3, pp. 567-570, 2015.
- [6] A. Elrashidi, K. Elleithy, and H. Bajwa, "The fringing field and resonance frequency of cylindrical microstrip printed antenna as a function of curvature," *Eurasip Journal Wireless Communication Networking*, vol. 3, pp. 1-12, 2012.
- [7] T. Onishi and I. Fukai, "Analysis of microstrip antennas on a curved surface using the conformal grids FDTD method," *IEEE Transactions on Antenna Propagation*, vol. 42, pp. 423-427, 1993.
- [8] G. Gottwald and W. Wiesbeck, "Radiation efficiency of conformal microstrip antennas on cylindrical surfaces," *Antenna Propagation Society International Symposium AP-S. Digest*, vol. 4, pp. 1780-1783, 1995.
- [9] D. Correias-Serrano, J. S. Gomez-Diaz, J. Perruisseau-Carrier, and A. Alvarez-Melcon, "Graphene based plasmonic tunable low pass filters in the THz band," *Nano Technology, IEEE Transactions*, vol. 3, pp. 1145-1153, 2014.
- [10] K. Luk, K. Lee, and J. S. Dahele, "Analysis of cylindrical-rectangular patch antenna," *IEEE Transactions on Antenna Propagation*, vol. 37, pp. 143-147, 1989.
- [11] G. W. Hanson, "Dyadic green's functions and guided surface waves for a surface conductivity model of graphene," *Journal Applied Physics*, vol. 103, pp. 064302, 2008.
- [12] M. E. Morote, J. Sebastian, J. S. Gomez-Diaz, and J. Perruisseau-Carrier, "Sinusoidally-modulated graphene leaky-wave antenna for electronic beamscanning at THz," *IEEE Transactions Terahertz Science Technology*, vol. 4, pp. 116-122, 2014.
- [13] CST Microwave Studio Suite, User's Manual Computer Simulation Technology, Framingham, MA, USA, 2014.
- [14] R. Bala and A. Marwaha, "Investigation of graphene based miniaturized terahertz antenna for novel substrate materials," *Elsevier Journal on Engineering Science and Technology, an International Journal*, ISSN: 2215-0986, pp. 1-7, 2015.
- [15] M. Dragoman and D. Dragoman, "Graphene for microwaves," *IEEE Microwave Magazine*, vol. 11, pp. 81-86, 2010.
- [16] S. Ghosh, I. Calizo, D. Teweldebrhan, et al., "Extremely high thermal conductivity of graphene: Prospects for thermal management applications in nanoelectronic circuits," *Applied Physics Letter*, vol. 92, iss. 15, pp. 151911, 2008.
- [17] T. J. Balandin, P. Blake, R. R. Nair, et al., "Macroscopic graphene membranes and their extraordinary stiffness," *Nano Letter*, vol. 8, iss. 8, pp. 2442-2446, 2008.
- [18] C. Lee, X. Wei, J. Kysar, and J. Hone, "Measurement of the elastic properties and intrinsic strength of monolayer graphene," *Science*, vol. 321, pp. 385-388, 2008.
- [19] E. S. Ahmed, "Wearable conformal antennas for 2.4 GHz wireless body area networks," *Telkomnika*, vol. 11, pp. 175-180, 2013.
- [20] J. R. James and P. S. Hall, *Handbook of Microstrip Antennas*, Peter Peregrinus, ISBN: 0-86341-150-9, London, 1989.
- [21] J. Bahl and P. Bhartia, *Microstrip Antennas*, Artech House, Dedham, MA, 1980.
- [22] I. Llatser, C. Kremers, D. Chigrin, J. Jornet, M. Lemme, A. Cabellos-Aparicio, et al., "Characterization of graphene-based nano-antennas in the terahertz band," *Antennas and Propagation (EUCAP), 6<sup>th</sup> European Conference*, pp. 194-198, 2012.

- [23] R. Bala, A. Marwaha, and S. Marwaha, "Performance enhancement of patch antenna in terahertz region using graphene," *Current Nanoscience, Bentham Science*, ISSN: 1875-6786 (Online), ISSN: 1573-4137 (Print), vol. 11, pp. 1-7, 2015.
- [24] S. Akcoltekin, M. El Kharrazi, B. Kohler, A. Lorke, and M. Schleberger, "Graphene on insulating crystalline substrates," *Nanotechnology*, vol. 20, pp. 155601, 2009.
- [25] C. K. Wu and K. L. Wong, "Broadband microstrip antenna with directly coupled and gap coupled parasitic patches," *Microwave Optical Technology Letter*, vol. 22, pp. 348-349, 1999.
- [26] A. A. Deshmukh and K. P. Ray, "Compact broadband slotted rectangular microstrip antenna," *IEEE Antenna Wireless Propagation Letter*, vol. 8, pp. 1410-1413, 2009.
- [27] International Commission on Non-ionizing Radiation Protection, "Guidelines for limiting to time-varying electric, magnetic, and electromagnetic fields (up to 300 GHz)," Ed: Health Physics Society, 1998.
- [28] S. Sankaralingam and B. Gupta, "Development of textile antennas for body wearable applications and investigations on their performance under bent conditions," *Progress In Electromagnetics Research B*, vol. 22, pp. 53-71, 2010.
- [29] X. Huang, T. Leng, M. Zhu, et al., "Highly flexible and conductive printed graphene for wireless wearable communications applications," *Scientific Reports* 5, Article number: 18298, 2015.



**Rajni Bala** is presently working towards her Ph.D. at the Dept. of Electronics & Comm. Engg., SLIET Longowal, Deemed University. She obtained her M.Tech in (ECE) from SLIET Longowal, Deemed University in 2012 & B.Tech (Electronics and Communication Engg.) from MIMIT Malout, PTU Jalandhar in 2010. Her area of interest include Miniaturized Resonant THz antenna. She has published 24 research papers in refereed international and National journals and conferences.



includes curved patch antenna for biomedical applications.

**Rajdeep Singh** was born in Moga. He obtained his B.Tech in (ECE) from SLIET Longowal, Deemed University in 2014. He is presently working towards his M.Tech at the Dept. of Electronics & Comm. Engg., SLIET Longowal, Deemed University. His area of interest



**Anupma Marwaha** is Professor in Electronics & Communication Engineering Department at SLIET Longowal, Distt. Sangrur, Punjab. Post Doctorate from GNDU, Amritsar in the year 2003 with specialization in the field of 'Design and Field Analysis of Electromagnetic Devices by FEM with applications to Communication Engg., Microwave and Antennas'. She has more than 75 publications to her credit in International and National Journals in the area of antenna design, bio-electromagnetics and in microscale and nanoscale structures.



**Sanjay Marwaha** is working as Professor in the faculty of EIE Dept. at SLIET, longowal, Punjab. He got his Ph.D. from Guru Nanak Dev University Amritsar in year 2000. He has more than 22 years of teaching experience and has more than 100 papers to his credit in various National & International Conferences and Journals. He is the author of Basic of Electrical Engineering and Basic of Electrical & Electronics Engineering; Satya Prakashan.