

Multiple Human Targets Detection and Localization Using Leaky Coaxial Cable Sensing Technique

Qiao Guan^{1,2}, Hongmin Lu^{1,2}, Chongchong Chen¹, and Chuanxia He²

¹ School of Electronic Engineering
Xidian University, Xi'an, Shaanxi 710071, China
guanqiao@stu.xidian.edu.cn, hmlu@mail.xidian.edu.cn, ccchen@stu.xidian.edu.cn

² Key Lab of High-Speed Circuit Design and EMC
Ministry of Education, Xidian University, Xi'an, Shaanxi 710071, China
guanqiao@stu.xidian.edu.cn, hmlu@mail.xidian.edu.cn, hechuanxia@stu.xidian.edu.cn

Abstract — Leaky coaxial cable (LCX) not only widely applies to the wireless communication systems, but also used as a LCX sensor for the intrusion detection systems (IDS). For evaluating the usability of the specialized LCX, the electrical parameters and the radiation pattern of the LCX sensor are measured. Moreover, in order to achieve the multiple targets localization, the novel location algorithm is proposed for the IDS based on the specialized LCX sensor in the VHF band. In this paper, the multiple targets are identified precisely by the synchronous subtraction, the time-domain digital pulse compression and the window function. By emitting a chirp signal into the LCX sensor, the echo signal containing the targets' response is received by the signal receiver (Rx). Then the pulse accumulation can be used for decreasing the noise signal in the digital signal processor (DSP), and the peak characteristics of the targets' echo signal are improved by the pulse compression and the Kaiser window function. Finally, by calculating the delay time of the echo signal after using the synchronous subtraction, the targets locations are obtained. The results show that transmission attenuation of the specialized LCX is 0.75 dB/100m and its coupling Loss is 71.63dB, and S_{11} is -39.9dB when the central frequency is 100MHz. The range resolution of the intruder detection system based on LCX sensor is as small as 3.32m and the positioning accuracy is less than 0.8m, which realizes the multiple targets detection and good localization results.

Index Terms — Aperture and pulse compressing, electromagnetic sensor, multiple targets.

I. INTRODUCTION

Leaky coaxial cable(LCX) is similar to the coaxial cable except the slotted apertures on its outer conductor.

Hence the LCX can achieve the wave radiation through the outer conductor by the aperture antenna theory [1]. Since the LCX has two functions that of the signal transmission and the electromagnetic wave radiation, the LCX has been applied in the perimeter intruder detection system (IDS), train communication and the MIMO application [2,3,4]. A LCX sensor consisting of two LCXs can be used in IDS, and these two specialized LCX are placed parallel. One LCX emits the detection signal, and the other LCX receives the echo signal, so the two LCXs form a detection area in space. By distinguishing the change of the echo signal, it will achieve the purpose of the target localization.

In practice, the modern IDS have higher requirements for the effective distance, the range resolution, the accuracy of measurement and the electronic countermeasures. Meanwhile, little attention has been devoted to the multiple targets localization, and most of IDS based on LCX sensor [5,6] cannot provide the good positioning accuracy and the range resolution.

In this paper, an IDS based on the LCX sensor for multiple targets localization is realized by introducing the synchronous subtraction, the pulse compression [7] and the window function. When the targets enter the LCX sensor detection area, the echo signal is subtracted synchronously, then the process of pulse compression and the Kaiser window function make the subtraction results in a good performance, which provide the good peak characteristics. In addition, the pulse accumulation can be used for decreasing the noise signal, which can improve the anti-interference ability and flexibility. Compared with the common IDS based on LCX sensor, the proposed signal processing algorithm has the advantages of the smaller range resolution and the higher positioning accuracy.

II. DESIGN OF INTRUDER DETECTION SYSTEM BASED ON LCX SENSOR

A. Location method

The structure of the LCX is different from that of the conventional coaxial cable. As shown in Fig. 1, the LCX consisted of the inner conductor, the insulation medium, the outer conductor and the sheath from inside to outside in sequence. The outer conductor is engraved with periodic slots. The coupling loss, the frequency band and the transmission attenuation are its important electrical performance indexes [8,9]. Table 1 shows the detail information of the LCX.

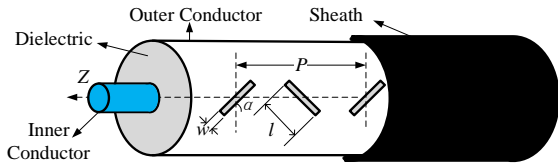

Fig. 1. Configuration of the leaky coaxial cable.

Table 1: The detail information of the LCX

Aperture		LCX	
Patch P	1 meter	Diameter of inner conductor	17.8 mm
Angle	45 deg	Thickness of outer conductor	0.1 mm
Width w	3 mm	Diameter of the insulation medium	42 mm
Length l	130 mm	Thickness of Sheath	8 mm

LCX sensor is composed of two identical LCX. As shown in Fig. 2, a chirp signal is transmitted from the signal source (Tx) once the IDS begin to work. When several targets step into the detection field which is established by the LCX sensor, the field will be disturbed and the target can be located by identifying the small disturbance.

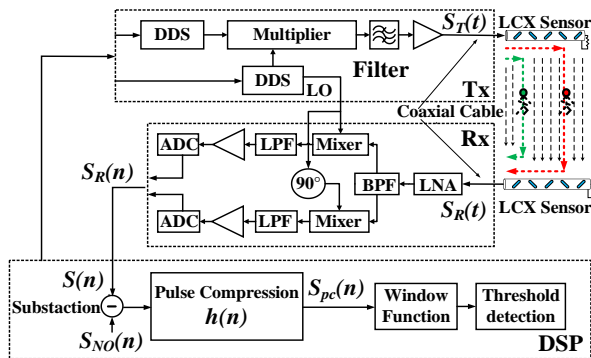

Fig. 2. IDS based on leaky coaxial cable sensor.

The chirp signal is defined in Fig. 3. The pulse width $t_R=100\text{ns}$, the pulse cycle $T_R =10\mu\text{s}$, the start frequency $f_a =80\text{MHz}$, the stop frequency $f_b =120\text{MHz}$, the bandwidth $B=f_b - f_a$, τ_1 and τ_2 are the delay time of echo signal that are reflected by the targets.

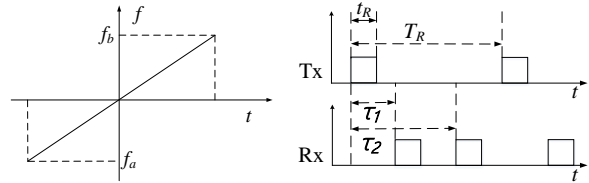

Fig. 3. Frequency and magnitude characteristics of the chirp.

The chirp signal can be written as:

$$s_T(t) = A \cdot \text{rect}\left(\frac{t-t_R/2}{t_R/2}\right) \cos(2\pi f_a t + \pi K t^2), \quad (1)$$

where A is the amplitude of the emitted chirp signal, Rect is a rectangular function, $K=B/t_R$.

When there are N targets entering the detection area at the same time, there will be N echo signals received by the Rx. In this case, these signals will be mixed after the reflections of those N targets. Assuming the delay time of the i -th echo signal is τ_i when chirp signal passes the i -th target. The mixed echo signal can be expressed as:

$$s_R(t) = \sum_{i=1}^N \{A_i \cdot \text{rect}\left(\frac{t-t_R/2-\tau_i}{t_R/2}\right) \cdot \cos[2\pi f_0(t-\tau_i) + \pi K(t-\tau_i)^2]\} \quad (2)$$

where A_i is the amplitude of the i -th echo signal and A_i is related to coupling loss and transmission attenuation [9,10]. The delay time $\tau_i = 2R/c$, where R is the distance from signal generator to the target, velocity of signal $c = c_0 / \sqrt{\mu_r \epsilon_r} = 0.887 \cdot c_0$, where c_0 is the velocity of electromagnetic in free space [11]. And signal transmitted slower in the LCX because of $\epsilon_r > 1$.

B. Pulse compression and windows function

Multiple targets are usually difficult to be identified precisely. To improve the positioning accuracy and the range resolution, it needs to do further approach of the echo signal. Therefore, the pulse compression need to be taken into consideration. On one hand, the pulse compression approach improves the average power of the detection signal by using a wide pulse width, so that it ensures the sufficient distance, On the other hand, the pulse compression improves the performance of the range resolution by using a narrow pulse width. Therefore, it is a good solution to solve the contradictions between the long detection distance and precise range resolution.

As Fig. 2 shown, assuming the chirp signal [12] is $S_T(t)$, the echo signal is $S_R(t)$, then by the matching filter theory [13], the unit impulse response of the filter $h(n)$ can be calculated by:

$$h(n) = S_T^*(N - n - 1). \quad (3)$$

The echo signal $S_R(n)$ is stored as $S_{NO}(n)$ in the DSP when there are no targets in the detection area. The output signal $S_{PC}(n)$ is the convolution of the subtraction signal $S(n)$ and the unit impulse response $h(n)$, which can be written as:

$$S_{PC}(n) = S(n) * h(n) = \sum_{k=0}^{N-1} S(k)h(n-k), \quad (4)$$

where $S(n) = S_R(n) - S_{NO}(n)$. The amplitude of $S_{PC}(n)$'s peaks suggest the size of the targets, the number of the $S_{PC}(n)$'s peaks suggest the number of the targets, and the delay time t_R of the $S_{PC}(n)$'s peaks provide the information of the targets' positions. Besides, the windows function can be used for optimizing the peak characteristics, which is benefit to judge the targets by considering the threshold for warning alarm.

According to Equation (2), the digital pulse compression process in time-domain is the linear convolution operation of the echo signal $S_R(n)$ and the unit impulse response $h(n)$. When the chirp signal $S_T(n)$ is emitted to detect the target and returns, the echo signal $S_R(n)$ corresponds to a certain distance range. Therefore, the output signal $S_{PC}(n)$ is related to an intrusion location when the echo signal $S_R(n)$ passes through the matched filter, then the position is got by calculating the delay time from the output signal $S_{PC}(n)$.

III. MULTIPLE TARGETS LOCALIZATION WITH THE PROPOSED METHOD

A. Leaky coaxial cable sensor

As shown in Fig. 1, LCX consists of inner conductor, insulation medium, outer conductor, and the sheath. The inner conductor is a cylinder made of copper, and the diameter of the inner conductor is 17.3 mm. The diameter of insulation medium is 43 mm, the degree of foamed PE dielectric is 76%, the dielectric constant is 1.247 and dielectric loss angle tangent is $1.7e-5$. The outer conductor is defined as a PEC in the simulation software. In addition, some apertures are on the outer conductor, whose width $w = 4$ mm, $P = 1000$ mm and angle $a = 45$ deg, the length of the aperture $l = 120$ mm. Table 2 illustrates the experimental and simulation results of LCX.

In Table 2, it can be seen that the LCX have a good match with the input port and the terminal port. The low transmission attenuation guarantees a long detection range, meanwhile, the coupling loss meets the requirement of the electromagnetic wave radiation. The

average S_{11} is -39.9dB in the simulation result, which illustrates the low reflection coefficient, therefore the leaky coaxial cable is well matched.

Table 2: Experimental and simulation results of the LCX (100 MHz)

Test Item	Simulation	Experiment
Characteristic impedance	51.3Ω	49.6Ω
Transmission attenuation	0.78dB/100m	0.75 dB/100m
Coupling loss	66dB	71.63dB
S_{11}	39.9dB	/

When the IDS works in the VHF band, the human target has the best response to the detection signal [13], which can avoid the false alarm caused by the small animal targets. Meanwhile, the relatively small transmission attenuation provides longer detection range. The radiation characteristics of the LCX are shown in Fig. 4.

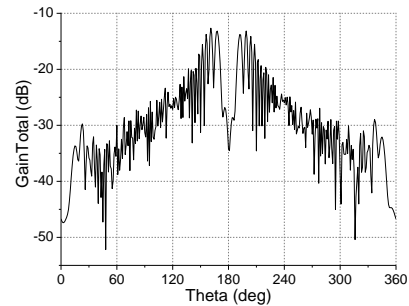

(a) 2-D Radiation pattern

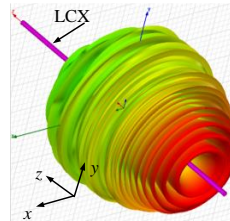

(b) Radiation characteristic in 3-D pattern

Fig. 4. Radiation patterns of the LCX in 2-D and 3-D.

The radiation pattern shows that the LCX sensor has a steady radiation electric field on its axis direction. Compared with the traditional antenna, radiation pattern of the LCX has no main lobe with high radiation ratio and the front-to-rear ratio in Fig. 4, but LCX has an annular main lobe which is called the maximum radiation direction. In this case, the echo signal is possible and easy to be reflected directly by the targets and be transmitted to the Rx. In other words, when the target enters the detection area and disturbs the electromagnetic field, then the parameters of the original environment change, and the change suggests the position information.

B. The IDS based on LCX sensor

The multiple targets intrusion experiments were carried out as shown in Fig. 5 (a). Two stationary targets, namely No.1 target and No.2 target, stand in the axial of LCX sensor with the appointed distance, and there is no Doppler frequency shift and relative motion between the R_x and the targets. Figure 5 (b) is the illustration of the IDS, which consists mainly of T_x , R_x , LCX sensor and DSP .



(a) The multiple targets intrusion experiment

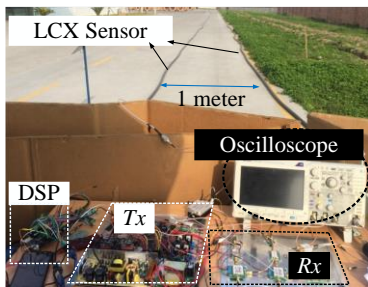

(b) The IDS based on LCX

Fig. 5. Multiple targets localization.

After the chirp signal emits (the pulse period $t_R = 100ns$, the pulse cycle $T=2\mu s$, the start frequency $f_a=80MHz$, the stop frequency $f_b=120MHz$), the echo signal is obtained and shown in Fig. 6.

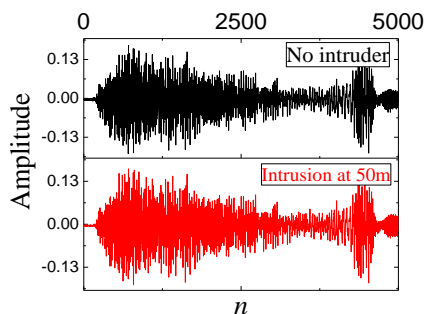

Fig. 6. The echo signal with and without human.

Where n is the sample sequence of the digital echo signal. Obviously, the response of the target information is mixed with the strong background noise.

As Fig. 7 shown, there is almost no difference between the system response and echo signal because the response of the target is too weak to distinguish from the system response, and the intruder information cannot be observed directly on those echo signals.

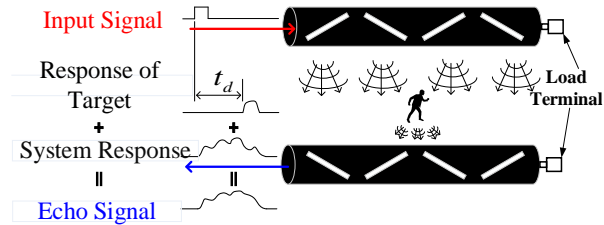

Fig. 7. Signal transmission characteristics.

In the experiments, those five different positions, namely 20m-30m, 10m-30m, 10m-50m, 10m-70m and 10m-90m are conducted respectively. When subtracting the echo signal without people from the normal echo signal with the two people echo signal synchronously after both echo signal is passing through the R_x , then the subtraction signal is obtained in Fig. 8, where there are two targets exist in the subtraction signal.

The pulse accumulation is a radar signal processing method, which can greatly reduce the noise of echo signal and improve the signal noise rate (SNR). Therefore, after the low-pass filter (LPF) and pulse accumulation, as shown in Fig. 8, it is easy to identify two targets by calculating the peaks of the five echo signals mentioned above. According to the radar principle, the range resolution of the IDS based on LCX sensor is $c \cdot t_R = 13.3m$ generally, while the range resolution can reach $c / 2 \cdot B = 3.32m$ after the pulse compression. Therefore, the echo signal will be aliasing and unable to identify multiple targets without the pulse compression when the distance between multiple targets is less than 13.3 meters. However, the multiple targets can be identified easily after the pulse compression as long as the distance between multiple targets is more than 3.32 m in theory.

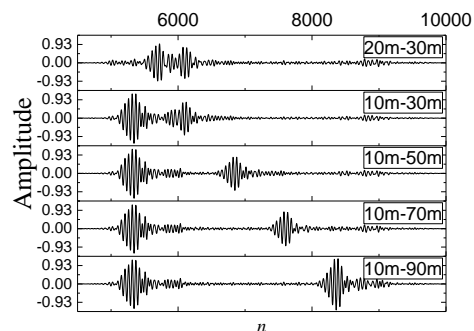

Fig. 8. Pulse compressing approach in 5 cases.

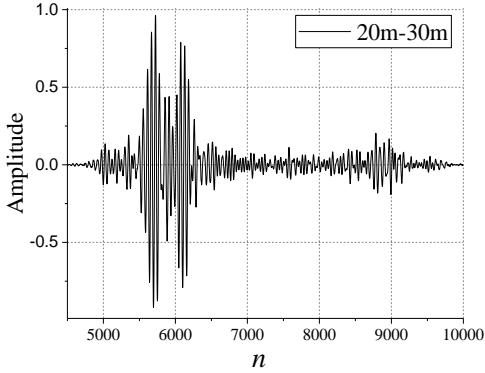

Fig. 9. The 20m-30m case after the pulse compression and the Kaiser window function.

However, the echo signal of two targets is indistinguishable in the 20m-30m case, which suggests a worse range resolution. In Fig. 9, it is easy to notice two peaks obviously by introducing the Kaiser window function after the pulse compression signal for further improvement in 20m-30m case.

Finally, a six-targets experiment is analyzed. The positions of the multiple targets are 10m, 20m, 30m, 50m, 70m and 90m along the axis of the LCX sensor. As Fig. 10 shown, the digital signal processing result of the six targets is obtained by the method including the subtraction synchronously, the pulse compression and the window function processing. Moreover, this method can achieve the high detection rate by identifying multiple targets. Setting the proper alarm threshold can improve the detection probability and reduce the failed detection rate.

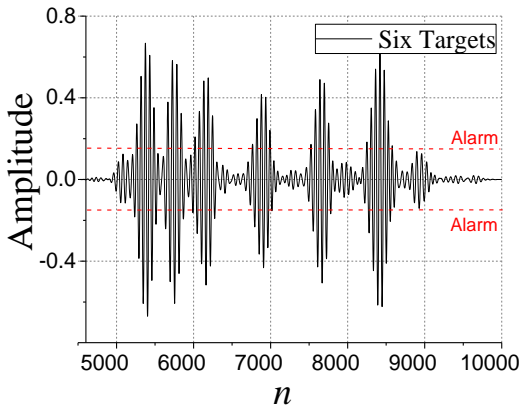

Fig. 10 Multiple targets detection result

The method can achieve high detection rate by identifying multiple targets. Setting the proper alarm threshold can improve the detection probability and reduce the failed detection rate and false alarm rate. The distance between the target and the transmitter can be calculated by the delay time of the chirp signal and the

echo signal. Table 3 is the detail information of the multiple targets localization result. For example, the IDS recognized the sample sequence $n=5348$ when the target is at the 10m (measured position), in this case, the delay time τ can be calculated by n , and the corresponding τ is 75.98ns. Then the calculated position can be obtained by:

$$R = \frac{\tau \cdot 0.887 \cdot c_0}{2} = 10.11 \text{ (m)}. \quad (5)$$

Table 3: The comparison of measured and calculated result of targets position

Sequence n	Delay Time τ_i	Measured Position	Calculated Position
5348	75.98 ns	10 m	10.11 m
5718	149.72ns	20 m	19.92 m
6093	221.17 ns	30 m	29.43 m
6849	378.45 ns	50 m	50.36 m
7609	523.42 ns	70 m	69.65 m
8363	682.51 ns	90 m	90.80 m

According to the difference between the measured positions and calculated positions, the new method reduces the range resolution and realizes the multiple targets localization of the IDS based on LCX sensor, and the positioning accuracy is about 0.8 m. Therefore, the pulse compression of the echo signal and the window function are introduced to optimize its peak characteristics of the targets, which proves to be an effective method for the multiple targets identification and localization.

VI. CONCLUSION

For perimeter intruder detection system based on the specialized LCX sensor, a new method consists of the digital pulse compression and the window function for improving peak characteristics of the target is proposed in this paper. The position of target can be determined by calculating the delay time after the subtraction synchronously, the low pass filtering processing, the pulse compression and the window function processing. The method mentioned above improves the range resolution and positioning accuracy. The multiple targets localization is achieved with the chirp signal (frequency range: 80MHz~120MHz). The range resolution is 3.32m, and the positioning accuracy is below 0.8m. The remote distance target localization and the environmental adaptability will be the next research work.

ACKNOWLEDGMENT

This work was supported by the Fundamental Research Funds for the Central Universities (JB160205).

REFERENCES

[1] J. H. Wang and K. K. Mei, "Design of leaky

- coaxial cables with periodic slots,” *Radio Science*, vol. 37, no. 5, pp. 1-10, 2016.
- [2] Q. Guan, C. C. Chen, and C. X. He, “A novel sensor using VHF zigzag-slotted leaky coaxial cable for intruder localization,” *Microw. and Opti. Tech. Lett.*, no. 60, pp. 634-639, 2018.
- [3] S. Okada, T. Kishimoto, K. Akagawa, et al., “Leaky coaxial cable for communication in high speed railway transportation,” *Radio & Electronic Engineer*, vol. 45, no. 5, pp. 224-228, 2010.
- [4] Y. Wu, G. Zheng, and T. Wang, “Performance analysis of MIMO transmission scheme using single leaky coaxial cable,” *IEEE Anten. & Wirel. Propa. Letters*, no. 16, pp. 298-301, 2017.
- [5] Q. Guan, X. F. Fan, Y. Liu, et al., “Research on VHF buried sensor using leaky coaxial cable techniques,” *Journal of Microw.*, vol. 33, no. 4, pp. 16-20, 2017.
- [6] K. I. Nishikawa, T. Higashino, K. Tsukamoto, et al., “Two dimensional position detection method using bi-directional leaky coaxial cable based on TDOA,” *IEEE Interna. Symp. on Personal, Indoor and Mobile Radio Commu.*, Tokyo, pp. 2167-2170, 2009.
- [7] A. Johnston, “Improvements to a pulse compression radar matched filter,” *Radio & Electronic Engineer*, vol. 53, no. 4, pp. 138-140, 1983.
- [8] C. Zhang, J. Wang, M. Chen, et al., “Radiation characteristic of the leaky circular waveguide with periodic slots,” *IEEE Anten. & Wirel. Propaga. Lett.*, vol. 11, no. 11, pp. 503-506, 2012.
- [9] A. Guan, C. C. Chen, and B. X. Song, “A study of designing circular polarization for leaky coaxial cable at 900 MHz,” *Progr. in Electromag. Research Lett.*, vol. 76, pp. 39-46, 2018.
- [10] J. H. Wang, “Leaky coaxial cable with circular polarization property,” *IEEE Transa. on Anten. and Propag.*, vol. 59, no. 2, pp. 682-685, 2011.
- [11] Y. Du, W. Li, Y. Ge, et al., “A high-frequency signal generator based on direct digital synthesizer and field-programmable gate array,” *Review of Scientific Instruments*, vol. 88, no. 9, pp. 096-103, 2017.
- [12] H. L. Pei, T. D. Abhayapala, and T. A. Lamahewa, “Multiple targets localization using wideband echo chirp signals,” *IEEE Transactions on Signal Processing*, vol. 61, no. 16, pp. 4077-4089, 2013.
- [13] A. Bergman, T. Langer, and M. Tur, “High spatial resolution, low-noise brillouin dynamic gratings reflectometry based on digital pulse compression,” *Optical. Letters*, vol. 41, no. 15, pp. 3643-3646, 2016.



Qiao Guan received the B.S. and M.S. degrees from the School of Electronic Engineering, Xidian University, Xi’an, China, in 2013 and 2015. He is currently pursuing his Ph.D. degree of the Electromagnetic and Microwave Technology in Xidian University. His research interest in the electromagnetic sensor, radar signal detection and estimation, electronics, and RF circuits.



Hongmin Lu, Professor, Ph.D. of Xi’an Jiaotong University, Postdoctoral Dellow of Xidian University of Electronic Science and Technology. Now he is a Professor at Xidian University, Chairman of Telecommunications Engineering Department, a Professor of National Key Laboratory of Antenna and Microwave Technology. His current research interests include the theory of high speed circuit and electromagnetic compatibility.