

FEKO Simulation of a Wedge Mounted Four Element Array Antenna

Steven Weiss¹, Keefe Coburn¹, and Ozlem Kilic²

¹U.S. Army Research Laboratory
2800 Powder Mill Road
Adelphi, MD 20783
sweiss@arl.army.mil,

²Department of Electrical Engineering and Computer Science
The Catholic University of America, Washington, DC 20064, USA
kilic@cua.edu

Abstract—A four element patch array with main beam locations approaching endfire has been developed. The initial design was accomplished using EMAG's EMPicasso software. The array is intended to be used in a monopulse configuration on the sides of a wedge-like structure. As such, accurate estimations of the patterns need to be obtained when the antenna is mounted on the geometry of the wedge. These simulations were not possible with 2.5 dimensional software, such as EMPicasso (www.emagware.com). We present measured data as compared to simulations using FEKO (www.feko.info) software for the array on a wedge.

Index Terms: FEKO, EMPicasso, patch array, monopulse array, conformal antenna

I. OVERVIEW OF THE ANTENNA ARRAY

Designing antennas that conform to a particular structure has potential use for military applications, [1]-[3]. One such design under consideration is a 1x4 linear patch array that has been developed at 9.35 GHz. The application required the antenna to be mounted on a wedge shaped structure with its main beam locations approaching endfire. An aperture fed patch antenna as shown in Figure 1 was designed to meet these specifications. The spacing between the elements is 0.877 wavelengths, resulting in an overall size (including the patch length) of 10.4 cm. The substrate is Rogers RT/Duroid 5880 for which we use $\epsilon_r = 2.33$ and $\tan\delta = 0.0002$ in these simulations. The initial development was accomplished using EMAG's

EMPicasso software. This Method of Moments (MoM) simulation uses the 2.5-D Mixed Potential Integral Equation (MPIE) formulation of planar structures [4, 5]. The FEKO MoM software also has this formulation for planar structures but in addition can simulate 3-D objects combined with planar geometries [6]. FEKO uses the Fast Multipole Method (FMM) to save memory for electrically large problems and has advanced features such as hybrid techniques with the Finite Element Method (FEM) and with approximate high frequency methods [7, 8]. For example, in FEKO the antenna substrate can be infinite in extent while the ground plane is a finite size, or vice versa. Thus EMPicasso provides approximate results for actual microstrip antennas where the largest differences are observed in the calculated pattern compared to measurements.

We note some unusual aspects of the array at the onset of this discussion:

- (1) The resonant length is such that one wavelength (within the dielectric) is traversed along the length of the element as opposed to a half wavelength, which is the typical size for patch antennas. As a consequence, the electric fields at the radiating edges of the patch are 180 degrees out of phase, [8] causing a null on broadside and main beams approaching endfire as shown in Figure 2.
- (2) In an effort to keep the sidelobe levels down, the array was excited with amplitude weights of: 1: 2: 2: 1 through the use of current dividers at the junction of the power splitters as shown in the right-hand side of Figure 3.

- (3) For a half wavelength patch, the aperture is typically placed at the center where the magnetic field peaks. The patch length in this example is one wavelength. Therefore, the magnetic field has two peaks located $\frac{1}{4}$ wavelength from each radiating edge instead of the center of the patch, [10]. Consequently, there are two optimal placements of the aperture. For the first element in the array, the patch is fed $\frac{1}{4}$ wavelength from its left edge. In order to have the radiation from the second patch contribute in phase, we have opted to feed the second patch $\frac{1}{4}$ wavelength from its right edge with a feed in the opposite direction to the first feed. The opposite locations of the aperture and the opposite orientation of the feed directions both introduce a 180 degree phase shift and allow for in-phase excitation of the two elements. The same feeding structure is repeated in the next pair of patches, so all patches radiate in phase.

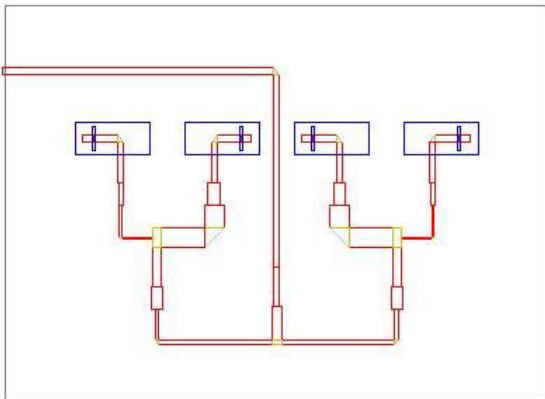

Figure 1. Outline of four element array developed using EMAG Picasso.

II. SIMULATIONS OF THE ANTENNA ARRAY

Some preliminary simulations have been run using FEKO to account for the finite ground plane of the array. First the single patch element was modeled using FEKO with a multilayer Green's function model for the substrates but finite size ground plane. We note that special attention had to be given to the meshing about the perimeter of both the patch and the aperture and in FEKO this is user defined. Some of these refinements are evident in Figure 4 where the ground plane mesh size

increases with distance from the slot aperture. More difficult to see is that the ground plane beneath the microstrip is meshed more finely also in the same manner as the strip conductors. This is a key step in obtaining a reasonable estimation of the impedance match.

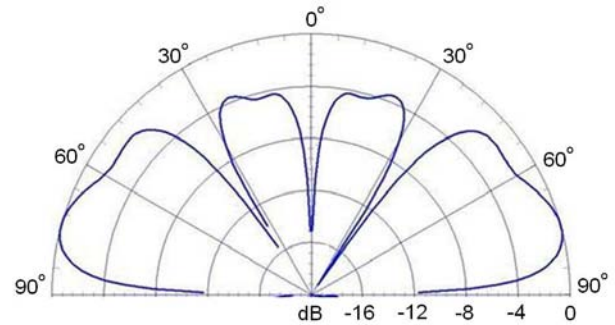
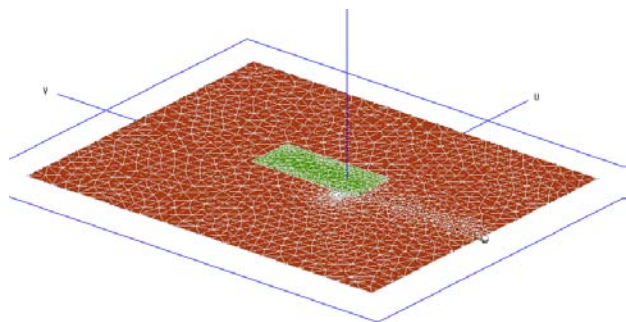

Figure 2. Radiation pattern of the array using EMAG Picasso.

The microstrip line was excited via a probe. The simulated return loss for the patch antenna is presented in Figure 5, which shows a better than 25 dB return loss at 9.35 GHz using FEKO. The simulated E-plane antenna pattern for this single element is shown in Figure 6. Note the symmetric and idealized nature of the EMPiCASSO backplane pattern compared to the finite ground plane result where the back lobes are not symmetric since the slot is not symmetric with respect to the patch. This



patch will be used in the array estimation of the problem and then applied to the wedge geometry.

Figure 3. Mesh refinements for simulation of a single patch on a ground plane.

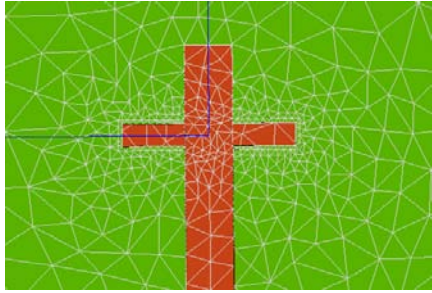

Figure 4. Mesh refinements about the feed line and the aperture beneath the patch.

Figure 5. Computed return loss using Picasso (infinite ground plane - top) and FEKO (finite ground plane - bottom.)

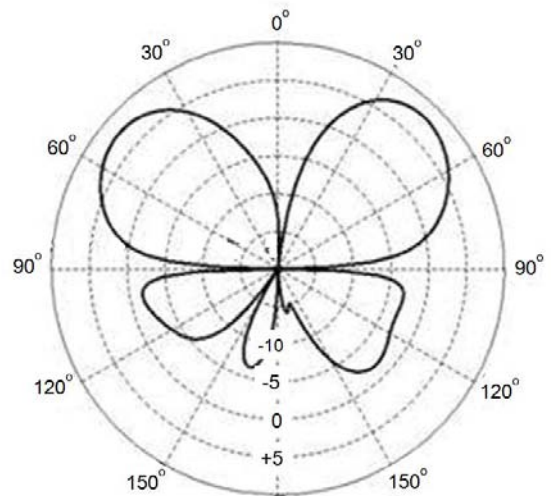
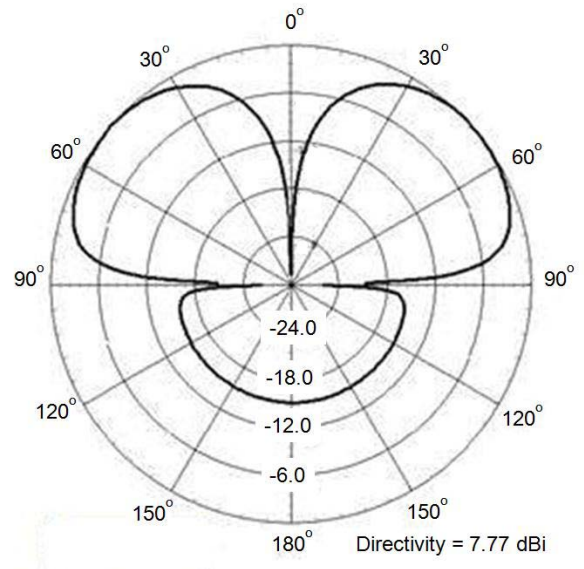
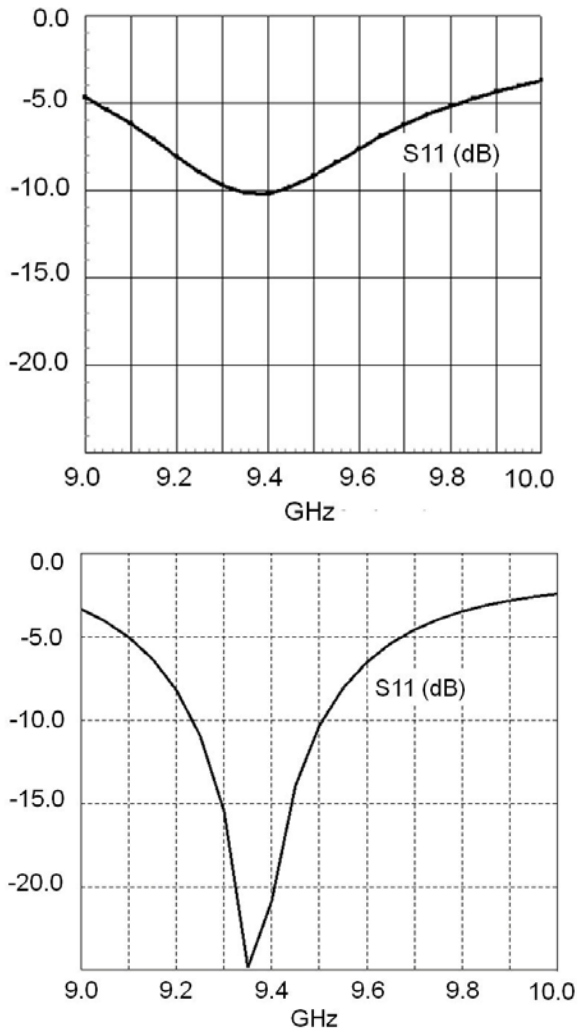

Figure 6. Computed radiation patterns using Picasso (infinite ground plane) and FEKO (finite ground plane)

III. OPERATIONAL DETAILS OF THE ANTENNA

This antenna was developed to operate on the sides of a wedge in a monopulse configuration and would require at least two arrays on either side of the conducting wedge as shown in Figure 7. This is the actual structure from which our measurements were taken. Notice that the metal ground plane extends around all sides of the antenna arrays. Figure 8 gives the monopulse pattern of the two

antenna arrays mounted on the wedge and fed in phase. It shows the characteristic forward null of the monopulse configuration. Measurements of the pattern are presented to demonstrate the potential of this technique to determine the direction of a target.



Figure 7. Actual array(s) placed on a slanted (wedge) ground plane.

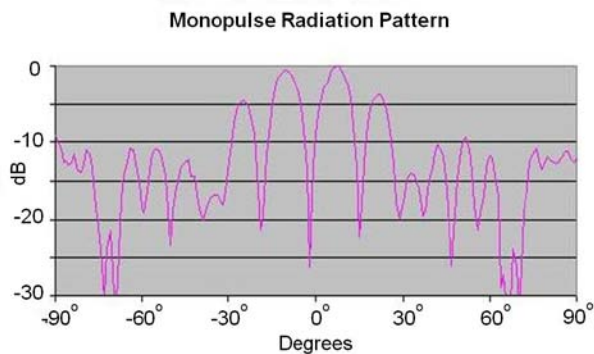

Figure 8. Measured monopulse normalized radiation pattern.

IV. SIMULATIONS OF THE WEDGE CONFIGURATION

All simulations for this section used a dual core XEON 5150, 2.66 GHz machine with 16 GB DDR2 RAM and a 533 MHz bus. The operating system was Red Hat LINUX 64-bit and CAD FEKO Version 2.0.5 (FEKO Suite 5.2) was used. The multilevel fast multipole method (MLFMM) was used which save memory and run-time compared to standard MoM [6]. A convergence study confirmed that the mesh refinement was adequate and that the ground plane mesh size can increase away from the microstrip line. The coarser mesh provided a more

efficient simulation without reducing accuracy and required about 5 hrs per frequency.

Actual simulations (FEKO) of the wedge proved time consuming because of the size of the problem. In Figure 9 we detail the geometry of a FEKO simulation using a planar geometry. Such a simulation lends itself to a 2.5 dimensional Green's function solution so the dielectric lateral dimensions can be unbounded in the x-y plane (seen as the region about the finite ground plane of the patch.) This solution ran reasonably fast – on the order of 1 hr per frequency depending on the requested output. For this smaller problem the FMM does not provided a significant memory reduction. The patterns for this simulation are not shown.

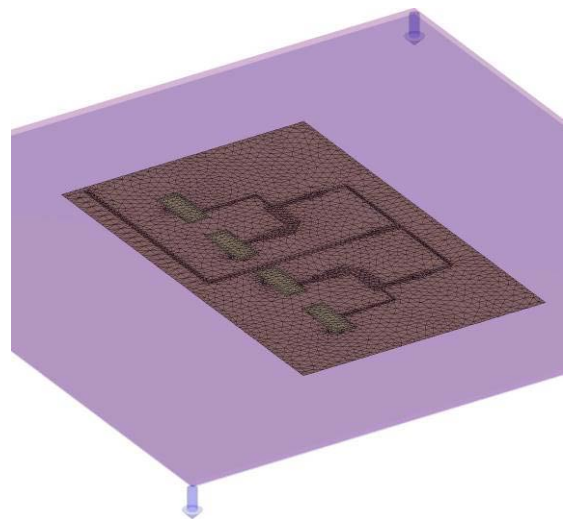

Figure 9. FEKO simulation using a Green's function model for the substrate.

Simulations of the wedge were more challenging because the Green's function approach only lends itself to problems residing on planar geometries. In Figure 10, we show our configuration for two 4-element array antennas mounted on a wedge. For this simulation, the ground plane extends the length of either side, but the dielectric is terminated and does not extend to the actual tip of the wedge using the Surface Equivalence Principle (SEP) to represent the dielectric surfaces rather than a volume mesh. Now the problem size is significantly larger and the FMM provides substantial memory reduction from ~60 GB to less than 2 GB. Termination of the dielectric region was necessary to match the

demonstration wedge array configurations although the ground plane on the sides of the arrays was not simulated (see Figure 7). The actual tip of the wedge, Figure 11, was simulated as a flat surface, ensuring a symmetrical mesh on either side of the wedge.



Figure 10. Two 4-element array antennas mounted on a wedge.

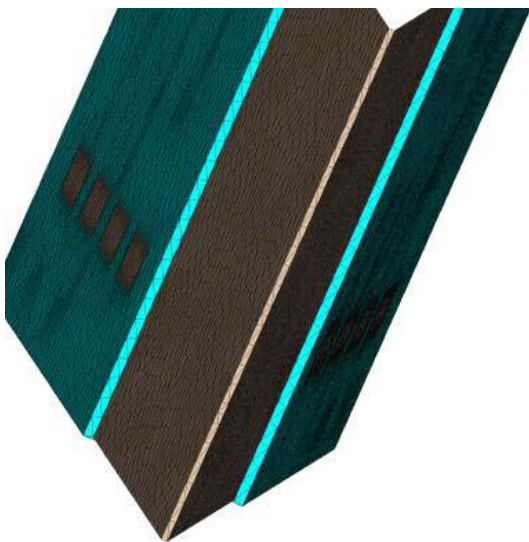

Figure 11. FEKO implementation of the wedge tip.

In Figure 12, we present a simulation model that closely approximated the fabricated wedge that was measured. Note the inclusion of a flat metallic disc suppressing radiation to the back direction.

This was consistent with the metal base plate of the anechoic chamber mast as used in the measurement.

In Figure 13, we present the simulated radiation patterns (FEKO) for both the wedge and the wedge with the back plate at a frequency of 9.45 GHz. The simulation results should be compared to the measured data of Figure 8.



Figure 12. FEKO wedge model with a metallic back plate.

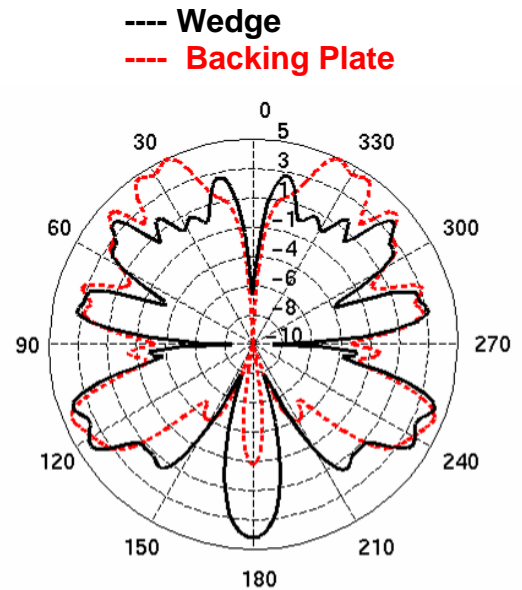

Figure 13. Simulated patterns for the two wedge configurations.

The measured peak locations and the simulation *without* the backplane closely track at about 10 Degrees from the plane containing the wedge's tip. However, the simulation predicts a broad side lobe only 3 dB below the main lobe whereas the data indicates a distinctive first side lobe with back lobes 10 dB below peak. The lack of a back plane predicts a major lobe at 180° in contrast to measured data. The inclusion of a back plane suppresses the back radiation in the computer simulation, but widens the two peak locations to about 25°. The pattern has large side lobes possibly owing to smaller and more asymmetric ground plane surfaces transverse to the arrays.

An even larger mesh would be required to adequately simulate the ground plane used in the measurements. The problem quickly requires more memory than available on most desktop workstations and parallel computing or approximate methods may be required [7]. To conserve computational resources a coarse mesh could be used on the back plate and ground plane sections removed from the antennas with a corresponding reduction in accuracy. Other approximate methods such as Physical Optics are not appropriate for this array [8]. The MoM is typically more efficient than finite difference methods for such large arrays over narrow bandwidths. The finite element method is an alternative that can be efficient since the matrix is sparse and can take advantage of fast solvers. Regardless of the chosen method, compromises are often required to obtain an adequate mesh resolution of the array within the available computational resources.

V. CONCLUSIONS

This paper discusses a unique patch array designed for use on a wedge in a monopulse configuration. The original design was accomplished with 2.5 dimensional MoM software (EMPicasso). FEKO was used to investigate the effect of a finite size ground plane showing that the 2.5 dimensional model was adequate for the forward radiation pattern but results in an idealized backplane pattern. The antenna arrays were placed on a wedge structure for measurements. FEKO was used to simulate the wedge ground plane; however, the inclusion of a conducting back plane needs further investigation. It is needed (and was present in the measurements) for suppression of back

radiation, but in our limited size model it degrades the position of the forward beam. A larger ground plane is required in the simulation but results in a problem nearing the limits of our available RAM. Improved accuracy can often be obtained in FEKO by using the MoM/FEM hybrid technique which uses an FEM volume mesh in the dielectric substrate. A microstrip edge source in FEKO can also improve accuracy compared to a thin-wire probe feed. A refined model will be developed to investigate such alternatives and include the as-tested ground plane size. Based on the available computational resources, some tradeoffs in accuracy are often necessary in order to develop a practical yet realistic simulation.

REFERENCES

- [1] O. Kilic and S. J. Weiss, "Conformal Antenna Design for Military Vehicle Armor," *Proc. IEEE AP-S and USNC/URSI*, Albuquerque, NM, 2006.
- [2] O. Kilic, A. Zaghoul, E. Kohls, R. Gupta, and D. Jimenez, "Flat Antenna Design Considerations for SOTM and SOTP Applications," Invited, *MILCOM*, vol. 2, pp. 790 – 794, 2001.
- [3] O. Kilic and A. Zaghoul, "Integrated Antenna System for Blockage and Interference Mitigation for Satellite-on-the-Move (SOTM) Communications," *Proc. 23rd Army Science Conference*, Orlando, FL, Dec 2-5, 2002.
- [4] K. F. Sabet, *Novel Efficient Integral Equation Based Techniques for Characterization of Planar Microwave Structures*, Ph.D. dissertation, University of Michigan, April 1995.
- [5] K. F. Sabet, J. Cheng, K. Sarabandi, and L. Katehi, "An Advanced Electromagnetics Tool for Design of Multilayer Printed Antenna Arrays," at www.emagtechnologies.com.
- [6] J. van Tonder and U. Jakobus, "Fast Multipole Solution of Metallic and Dielectric Scattering Problems in FEKO," *Applied Computational Electromagnetics Society (ACES) Conference*, 2005.
- [7] U. Jakobus, "Application of Integral Equation and Hybrid Techniques to Parallel Computation of Electromagnetic Fields in a Distributed Memory Environment," *Applied Computational Electromagnetics Society (ACES) Journal*, Special Issue vol. 13, no. 2, 1998.

- [8] U. Jakobus, "Extension of MoM/PO Hybrid Technique to Homogeneous Dielectric Bodies," *Applied Computational Electromagnetics Society (ACES) Conference, Wash. D.C., 1998*.
- [9] J. R. James and P. S. Hall, *Handbook of Microstrip Antennas*, Chapter 2, Peter Peregrinus Ltd., London, UK. 1989.
- [10] F. Croq and D. Pozar, "Millimeter-Wave Design of Wide-Band Aperture-Coupled Stacked Microstrip Antennas," *IEEE Transactions on Antennas and Propagation*, vol. 49, no 12, pp. 1770-1776, Dec. 1991.



Ozlem Kilic graduated from The George Washington University in 1996 with a doctoral degree in Electrical Engineering. She is presently a professor with the Catholic University of America. Her research areas include computational electromagnetics, hardware accelerated programming for scientific computing and radiation and scattering problems from random media.



Steven Weiss was born in Utica, NY in 1955. He graduated from The George Washington University in 1995 with a doctoral degree in Electrical Engineering. He is presently with the Army Research Lab working on antenna systems. His research areas include specialized antennas for military applications.



William O'Keefe Coburn graduated from The George Washington University in 2005 with a doctoral degree in Electrical Engineering. Dr. Keefe Coburn has been with Army Research Laboratory (formerly Harry Diamond Labs) since 1981. His recent experience has been in CEM code development, verification and application in the areas of radar scattering and antennas for Army applications.